



Law Fest

INSTITUTE OF LAW

KURUKSHETRA UNIVERSITY, KURUKSHETRA

PRESENTS

राजीव फेस्ट



20 MARCH 2023

21 MARCH 2023

22 MARCH 2023



GUEST OF HONOUR
Prof. AMIT LUDRI
 DEAN & CHAIRMAN
 DEPARTMENT OF LAW
 KURUKSHETRA UNIVERSITY
 KURUKSHETRA



PATRON
Prof. SOM NATH SACHDEVA
 Hon'ble Vice-Chancellor
 KURUKSHETRA UNIVERSITY
 KURUKSHETRA



CHIEF GUEST
Dr. SANJEEV SHARMA
 Hon'ble Registrar
 KURUKSHETRA UNIVERSITY
 KURUKSHETRA



Prof. (Dr.) RAJPAL SHARMA
 DIRECTOR
 INSTITUTE OF LAW
 KURUKSHETRA UNIVERSITY
 KURUKSHETRA

Inaugural Ceremony
 Date: 20th March, 2023
 Time: 10:00 to 11:00 AM
 Venue: Institute of Law

Valedictory Ceremony
 Date: 22nd March, 2023
 Time: 3:00 to 4:00 PM
 Venue: RK Sadan



DR. MANJINDER GULYANI
 COORDINATOR
 VIDHIFIESTA 2023



DR. POONAM SHARMA
 ORGANISING SECRETARY
 VIDHIFIESTA 2023



DR. RAMESH SIROHI
 CO-COORDINATOR
 VIDHIFIESTA 2023



ABOUT INSTITUTE OF LAW

The Institute of Law, Kurukshetra University Kurukshetra, has the unique distinction of being the first law school in Haryana to start a B.A.LL.B (Hons.) 5-year Integrated Programme in 2001 and it has now entered its 23rd year of imparting excellence in legal education. The Institute provides excellent platform for the study of law in a dynamic environment. It has been ranked the seventeenth best law institute in India by India Today– Nielsen Survey in 2018. Set up in the holy city of Kurukshetra the Institute of law aims to develop in the students social and scientific research skills so as to enhance in them a sense of responsibility to serve the society as professionals. Besides classroom teachings, the Institute of law provides the students an opportunity to hone their skills by participating in several academic, co-curricular and extra curricular events.

ABOUT VIDHI FIESTA

Presenting the 2023 edition of Law Fest Organised by Institute of law, Kurukshetra University, Kurukshetra. With a host of Cultural and academic events to hit the ground running, it promise to be an experience that would be with the students long after it's over. To top it all off, we have trophies, cash prize and titles to be won and exhilarating Shows.

As the nomenclature suggests, VidhiFiesta , which means festival of law or legal events, itself fetches the aim to provide students with ample opportunities to show their creativity and hidden talent along with legal skills.

चौकीं फिस्ता



EVENTS



- PRATIBIMB
- PICCASHOW
- VIGYAFUN
- JUSTICIA
- COUNSEL CONNECT
- AVGAHAN
- RANBHOMI
- ANDAAZ-A-ALFAZ
- MANCH
- LE GALA
- PEHCHAAN
- KHANAK
- GOAL DIGGERS





Department of Geology
Kurukshetra University, Kurukshetra



invites you to participate in the

National Level Declamation Contest **on the theme "Geosciences and Society"**

Sub-themes:

**Atal Bhujal Yojana, Jal Jeevan Mission- Har Ghar Jal,
Namami Gange Programme, Jal Shakti Abhiyan- Catch the Rain,
National Water Mission, National Resources & Management,
Climate Change, Disaster Management**

Who can participate:

Undergraduate and Post Graduate students of any stream

Norms for Participants:

- 1. Student should be recommended from Department/Institute/ College and need to upload recommendation letter on Google form**
- 2. Medium for the contest will be either English or Hindi**
- 3. Duration: 3-5 minutes will be given to the candidate**
- 4. There will be two categories of the participants Undergraduate and Post Graduate**
- 5. e-certificates will be given to top three position holders in each category**



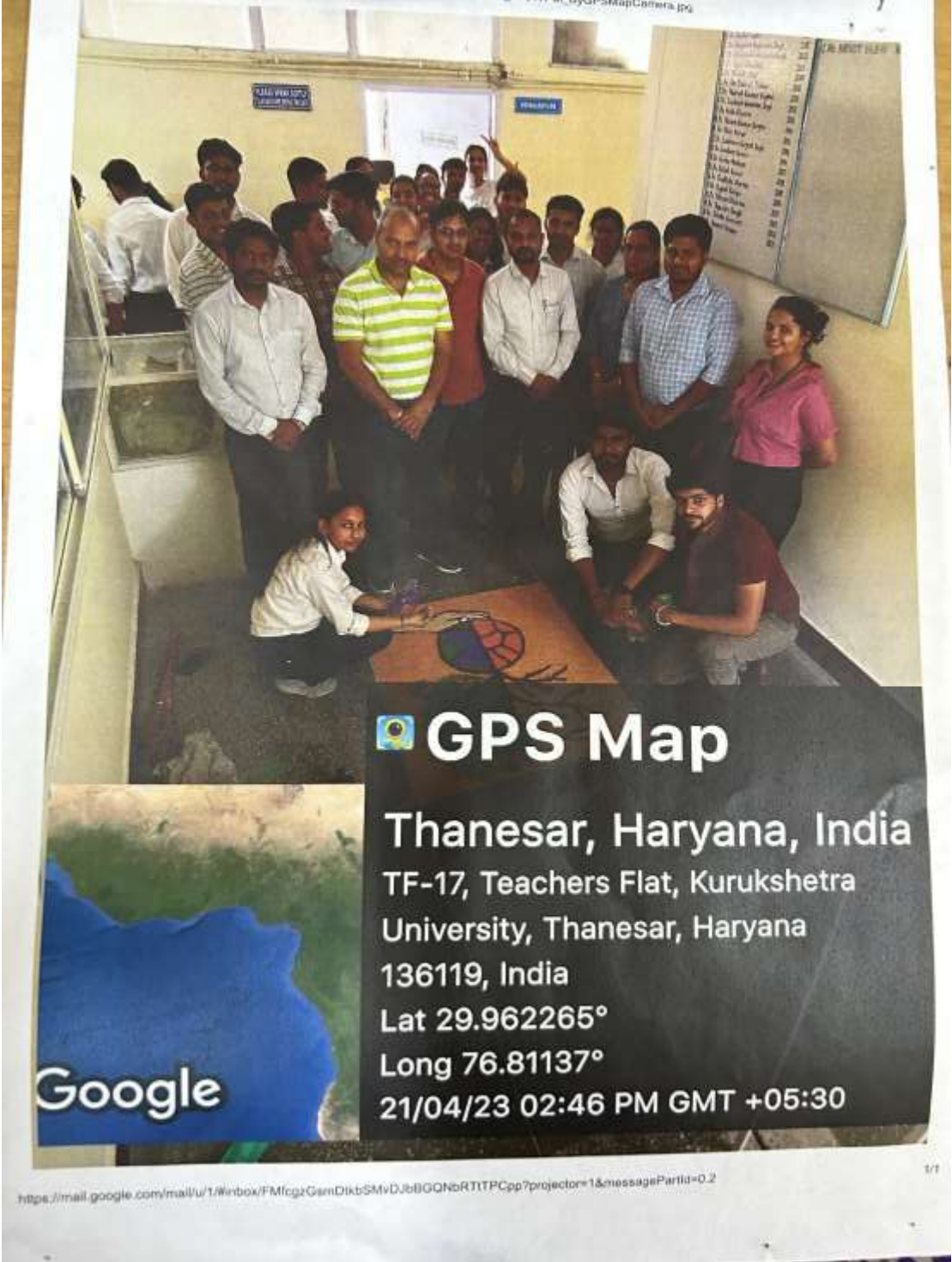

5.3.3 Average number of sports and cultural events / competitions organised by the Institution per year 2022-23

5.3.3.1: Number of sports and cultural events / competitions organised by the Institution during the year 2022-23

Date of event/competition (DD-MM-YYYY)	Name of the event/competition
14.08.2022	Quiz Competition
09.11.2022	Guest Lecture
12.12.2022	Educational Tour

Note: Classify the data and provide year wise

Document Required:

- (i) Report of the events alongwith geotagged photographs
- (ii) Copy of Circular/brochure indicating such events

Pa. Chairperson
Dep. of Sanskrit, Pali & Prakrit
Kurukshetra University,
KURUKSHETRA-136119.

5.3.3 Average number of sports and cultural events / competitions organised by the Institution per year 2022-23

5.3.3.1: Number of sports and cultural events / competitions organised by the Institution during the year 2022-23

Date of event/competition (DD-MM-YYYY)	Name of the event/competition
16-11-23	Deepamangalam
07-11-23	Poster Making Competition
25-10-23	Inter Department Cricket Tournament
04-03-23	Golden Jubilee Alumni Meet
20-10-22	Diwali Mela
23-07-22	Cultural and Educational Exchange session at State Senior Secondary School
25-01-22	Poster-making and declamation contest on the occasion of National Voter's day

Note: Classify the data and provide year wise

Document Required:

- (i) Report of the events alongwith geotagged photographs
- (ii) Copy of Circular/brochure indicating such events

Chairperson
University School of Management
Kurukshetra University,
KURUKSHETRA-136119.

यूनिवर्सिटी स्कूल ऑफ मैनेजमेंट के स्वर्ण जयंती कार्यक्रम में बोले वीसी

पूर्व छात्र किसी भी शैक्षणिक संस्थान की अमूल्य धरोहर

हरिभूमि न्यूज • कुरुक्षेत्र

कुरुक्षेत्र विश्वविद्यालय के कुलपति प्रोफेसर सोमनाथ सचदेवा ने कहा कि किसी भी किसी भी शैक्षणिक संस्थान के पूर्व छात्र उसकी अमूल्य धरोहर होते हैं जिसमें शैक्षणिक संस्थान को पहचान बनती है। उन्होंने कहा कि जीवन में प्रगति के लिए बुनियादी आधार पर एक मजबूत नींव की आवश्यकता होती है जिसके फलस्वरूप पूर्व छात्र शैक्षणिक संस्थान की नींव को मजबूती एवं आधार प्रदान करने का कार्य करते हैं। वे शनिवार को कुरुक्षेत्र विश्वविद्यालय के ऑडिटोरियम हॉल में कुवि के यूनिवर्सिटी स्कूल ऑफ मैनेजमेंट की स्थापना के 50वर्षों के गौरव और विरासत को चिन्हित करने के लिए आयोजित सारूप्य स्वर्ण जयंती पूर्व छात्र मिलन कार्यक्रम के उद्घाटन अवसर पर बतौर मुख्यातिथि बोल रहे थे। इस अवसर पर कुवि कुलपति प्रोफेसर सोमनाथ सचदेवा ने कहा कि पूर्व छात्र ही शैक्षणिक संस्थान की विशिष्ट पहचान होते हैं, इसलिए पूर्व छात्रों के अनुभवों के द्वारा विश्वविद्यालय की प्रगति के पथ पर अग्रसर किया जाना चाहिए। उन्होंने सभी पूर्व छात्रों से विश्वविद्यालय की बेहतरी एवं मजबूती के लिए



कुरुक्षेत्र। पूर्व छात्रों की स्मारिका का विमोचन करते कुलपति प्रो. सोमनाथ सचदेवा, भगत फूल सिंह महिला विश्वविद्यालय खानपुर कला की कुलपति प्रो. सुदेश छिन्नारा व अन्य। फोटो: हरिभूमि

मिलकर कार्य करने का आह्वान भी किया। इस अवसर पर भगत फूल सिंह महिला विश्वविद्यालय खानपुर कला की कुलपति प्रो. सुदेश छिन्नारा भी विशेष तौर पर मौजूद रही। इस अवसर पर यूएस, यूके, जर्मनी, आदि सहित भारत व दुनिया भर से 700 से अधिक पूर्व छात्रों ने इस भव्य आयोजन में भाग लिया, जिसमें उन्हें अपनी स्वर्णिम स्मृति रेखाओं को याद दिलाने में सक्षम बनना था। कार्यक्रम में पूर्व छात्र अमिताभ शर्मा, ने विभाग की मेधावी और वीर्य छात्राओं के लिए छात्रवृत्ति की शुरुआत की। सुधीर गुलिया और मनोहर सिंह (1979-81 बैच) ने विभाग के बुनियादी ढांचे के विकास के लिए राशि दान स्वरूप दी। शारदा, बंसल, और कई अन्य लोगों ने

डॉ. हरविन्द्र राणा ने दी बम लहरी पर विशेष प्रस्तुति

कुवि यूनिवर्सिटी स्कूल ऑफ मैनेजमेंट की स्थापना के 50 वर्षों के गौरवमयी इतिहास को लेकर आयोजित सारूप्य स्वर्ण जयंती पूर्व छात्र मिलन कार्यक्रम में हरिकाण कला परिषद के सौजन्य से कुलपति विश्वविद्यालय के युवा एवं जागरूक कार्यक्रम विभाग के डॉ. हरविन्द्र सिंह राणा ने बम लहरी कला पर चमत्कार प्रस्तुति वेक्टर ऑडिटोरियम हॉल में मौजूद सभी दर्शकों को झूमने पर राजमूर कर दिया। इस अवसर पर कुवि कुलपति प्रो. सोमनाथ सचदेवा से इस प्रस्तुति का सराहना की। केयू सुदामन की अध्यक्षता में निर्मला चौधरी ने भी पूर्व छात्रों के झुंझ बौं गढ़ इस प्रस्तुति के लिए डॉ. हरविन्द्र राणा का अभिनंदन व्यक्त किया।

सेवानिवृत्त शिक्षकों और छात्रों को उपहार भेंट स्वरूप दिए। स्वर्ण जयंती शोभायात्रा के बाद, यूनिवर्सिटी स्कूल ऑफ मैनेजमेंट की विभागाध्यक्ष, डॉ. निर्मला चौधरी ने विभाग की उपलब्धियों और इसके भविष्य के लिए एक दृष्टिकोण प्रस्तुत किया। कार्यक्रम में सभी पूर्व छात्रों को सम्मानित किया गया तथा इसके साथ ही पूर्व छात्रों

की स्मारिका के विमोचन और विभाग के पहले बैच द्वारा केक काटने की रस के साथ यह दिन और भी खास बन गया। इस मौके पर प्रो. रमेश चंद्र प्रो. सुशील शर्मा, प्रो. अनिल मितल, प्रो. सिद्धार्थ भारद्वाज, डॉ. सलोनी पी. दीवान, डॉ. अजय सोलंखे, डॉ. विवेक कुमार, डॉ. भंवर सिंह, और अन्य गणमान्य लोग मौजूद रहे।

Chairperson
University School of Management
Kurukshetra University,
KURUKSHETRA-136119.

केयू के यूनिवर्सिटी स्कूल ऑफ मैनेजमेंट ने मनाया स्वर्ण जयंती पूर्व छात्र मिलन समारोह जीवन में प्रगति के लिए मजबूत नींव की आवश्यकता होती है : सोमनाथ सचदेवा

भारत न्यूज़ | कुरुक्षेत्र

कुरुक्षेत्र विश्वविद्यालय के ऑडिटोरियम हॉल में केयू के यूनिवर्सिटी स्कूल ऑफ मैनेजमेंट की स्थापना के 50 साल पूरे होने पर स्वर्ण जयंती पूर्व छात्र मिलन समारोह आयोजित किया गया। इसमें मुख्यातिथि केयू कुलपति प्रो. सोमनाथ सचदेवा रहे। प्रो. सचदेवा ने कहा कि किसी भी शैक्षणिक संस्थान के पूर्व छात्र उसकी अमूल्य धरोहर होते हैं, जिससे शैक्षणिक संस्थान की पहचान बनती है। उन्होंने कहा कि जीवन में प्रगति के लिए बुनियादी आधार पर एक मजबूत नींव की आवश्यकता होती है। इसके फलस्वरूप पूर्व छात्र शैक्षणिक संस्थान की नींव को

मजबूती एवं आधार प्रदान करते हैं। इस अवसर पर यूएसए, यूके, जर्मनी सहित दुनियाभर से 700 से अधिक पूर्व छात्र शामिल हुए। पूर्व छात्र अमिताभ शर्मा ने विभाग की मेधावी और वंचित छात्राओं के लिए छात्रवृत्ति की शुरुआत की। सुधीर गुलिया और मनोहर सिंह (1979-81 बैच) ने विभाग के बुनियादी ढांचे के विकास के लिए राशि दान स्वरूप दी। शारदा बंसल और कई अन्य लोगों ने सेवानिवृत्त शिक्षकों और छात्रों को उपहार दिए। स्वर्ण जयंती शोभायात्रा के बाद यूनिवर्सिटी स्कूल ऑफ मैनेजमेंट की विभागाध्यक्ष प्रो. निर्मला चौधरी ने विभाग की उपलब्धियों और इसके भविष्य के लिए दृष्टिकोण प्रस्तुत



कुरुक्षेत्र केयू के स्कूल ऑफ मैनेजमेंट के 50 वें स्थापना दिवस समारोह में छात्रवृत्ति के लिए केयू कुलपति को चेक देते पूर्व छात्र।

किया। कार्यक्रम में सभी पूर्व छात्रों को सम्मानित किया और पूर्व छात्रों की स्मारिका का विमोचन किया गया। इस मौके पर प्रो. रमेश चंद्र, प्रो. सुरेश शर्मा, प्रो. अनिल मित्तल, प्रो. सिद्धार्थ भारद्वाज, डॉ. सलीमा दीवान, डॉ. अजय सोलंखे, डॉ. विवेक कुमार और डॉ. भंवर सिंह मौजूद रहे। डॉ. हरविंद राणा ने टी बग

लहरी की प्रस्तुति: केयू के यूनिवर्सिटी स्कूल ऑफ मैनेजमेंट की स्थापना के 50 वर्षों के गौरवमयी इतिहास को लेकर आयोजित स्वर्ण जयंती पूर्व छात्र मिलन कार्यक्रम में केयू के युवा एवं सांस्कृतिक कार्यक्रम विभाग के डॉ. हरविंद राणा ने बग लहरी भजन पर प्रस्तुति दी। इस प्रस्तुति पर सभी पूर्व छात्र भी झुमने लगे।

पूर्व छात्र शैक्षणिक संस्थान की पहचान: सचदेवा

जगरण सक्लपता कुरुक्षेत्र : कुरुक्षेत्र विश्वविद्यालय के यूनिवर्सिटी स्कूल ऑफ मैनेजमेंट में शनिवार को स्थापना के 50 वर्षों के लेकर सहाय्य स्वर्ण जयंती पूर्व छात्र मिलन कार्यक्रम हुआ। कार्यक्रम में बतौर मुख्यातिथि कुलपति प्रो. सोमनाथ सचदेवा ने कहा कि किसी भी शैक्षणिक संस्थान के पूर्व छात्र उसकी अमूल्य धरोहर होते हैं। इनसे शैक्षणिक संस्थान की पहचान बनती है।

उन्होंने कहा कि जीवन में प्रगति के लिए बुनियादी आधार पर एक मजबूत नींव की आवश्यकता होती है। यही पूर्व छात्र शैक्षणिक संस्थान की नींव को मजबूती एवं आधार प्रदान करने का कार्य करते हैं। उन्होंने कहा कि पूर्व छात्र ही शैक्षणिक संस्थान की विशिष्ट पहचान होते हैं। इसलिए पूर्व छात्रों के अनुभवों के द्वारा बिंबि को प्रगति के पथ पर अग्रसर किया जाना



यूनिवर्सिटी स्कूल ऑफ मैनेजमेंट की स्थापना दिवस पर कुलपति प्रो. सोमनाथ सचदेवा को पूर्व छात्र प्रो.सुरेश शर्मा ने टी बग लहरी प्रस्तुत की।

चाहिए। उन्होंने सभी पूर्व छात्रों से बिंबि की बेहतरी एवं मजबूती के लिए मिलकर कार्य करने का आह्वान भी किया। इस मौके पर पूर्व छात्रों ने भी कुर्बि पूर्व छात्र एसोसिएशन को करीब 20 लाख रुपये की राशि दान की। इस कार्यक्रम में यूएसए,

यूनाइटेड किंगडम व जर्मनी देरा भर से 700 के करीब पूर्व छात्रों ने हिस्सा लिया।

कार्यक्रम में पूर्व छात्र अमिताभ शर्मा ने विभाग की मेधावी और वंचित छात्राओं के लिए छात्रवृत्ति का शुरुआत करने का घोषणा की। सुधीर

गुलिया और मनोहर सिंह (1979-81 बैच) ने विभाग के बुनियादी ढांचे के विकास के लिए राशि दान स्वरूप दी। शारदा, बंसल सहित कई अन्य लोगों ने सेवानिवृत्त शिक्षकों और शिक्षार्थियों को उपहार भेंट किए। स्वर्ण जयंती शोभायात्रा के बाद यूनिवर्सिटी स्कूल ऑफ मैनेजमेंट की विभागाध्यक्ष प्रो. निर्मला चौधरी ने विभाग की उपलब्धियों और इसके भविष्य के लिए एक दृष्टिकोण प्रस्तुत किया। कार्यक्रम में सभी पूर्व छात्रों को अंग वस्त्र प्रदान कर सम्मानित किया गया। इसके साथ ही पूर्व छात्रों को स्मारिका का विमोचन किया गया और केट काटने की रस्म भी अंज की गई। कार्यक्रम में डॉ. हरविंद राणा ने बग लहरी पर बिंबि प्रस्तुति दी। इस मौके पर प्रो. रमेश चंद्र, प्रो. सुरेश शर्मा, प्रो. अनिल मित्तल, प्रो. सिद्धार्थ भारद्वाज, डॉ. सलीमा दीवान, डॉ. अजय सोलंखे, डॉ. विवेक कुमार मौजूद रहे।

Chairperson
University School of Management
Kurukshetra University,
KURUKSHETRA-136119.

पूर्व छात्र किसी भी शैक्षणिक संस्थान की अमूल्य धरोहर : प्रो. सचदेवा

कुरुक्षेत्र, यशबाबू न्यूज।

कुरुक्षेत्र विश्वविद्यालय के कुलपति प्रोफेसर सोमनाथ सचदेवा ने कहा कि किसी भी किसी भी शैक्षणिक संस्थान के पूर्व छात्र उसकी अमूल्य धरोहर होते हैं जिससे शैक्षणिक संस्थान की पहचान बनती है। उन्होंने कहा कि जीवन में प्रगति के लिए बुनियादी आधार पर एक मजबूत नींव की आवश्यकता होती है जिसके फलस्वरूप पूर्व छात्र शैक्षणिक संस्थान की नींव को मजबूती एवं आधार प्रदान करने का कार्य करते हैं। वे शनिवार को कुरुक्षेत्र विश्वविद्यालय के ऑडिटोरियम हॉल में कुवि के यूनिवर्सिटी स्कूल ऑफ मैनेजमेंट की स्थापना के 50वर्षों के गौरव और विरासत को चिह्नित करने के लिए आयोजित सारूप्य स्वर्ण जयंती पूर्व छात्र मिलन कार्यक्रम के उद्घाटन

अवसर पर बतौर मुख्यातिथि बोल रहे थे। इस अवसर पर कुवि कुलपति प्रोफेसर सोमनाथ सचदेवा ने कहा कि पूर्व छात्र ही शैक्षणिक संस्थान की विशिष्ट पहचान होते हैं। इसलिए पूर्व छात्रों के अनुभवों के द्वारा विश्वविद्यालय की प्रगति के पथ पर अग्रसर किया जाना चाहिए। उन्होंने सभी पूर्व छात्रों से विश्वविद्यालय की बेहतर एवं मजबूती के लिए मिलकर कार्य करने का आह्वान भी किया।

इस अवसर पर यूएस, यूके, जर्मनी, आदि सहित भारत व दुनिया भर से 700 से अधिक पूर्व छात्रों ने इस भव्य आयोजन में भाग लिया, जिसने उन्हें अपनी स्वर्णिम स्मृति रेखाओं को याद दिलाने में सक्षम बनाया। कार्यक्रम में पूर्व छात्र अमिताभ शर्मा, ने विभाग की मेधावी और वंचित छात्रों के लिए छात्रवृत्ति

की शुरुआत की। सुधीर गुलिया और मनोहर सिंह (1979-81 बैच) ने विभाग के बुनियादी ढांचे के विकास के लिए राशि दान स्वरूप दी। शारदा, बंसल, और कई अन्य लोगों ने सेवानिवृत्त शिक्षकों और छात्रों को उपहार भेंटस्वरूप दिए।

स्वर्ण जयंती शोभायात्रा के बाद, यूनिवर्सिटी स्कूल ऑफ मैनेजमेंट की विभागाध्यक्ष, डॉ. निर्मला चौधरी ने विभाग की उपलब्धियों और इसके भविष्य के लिए एक दृष्टिकोण प्रस्तुत किया, जो विभाग के प्रयासों को प्रतिबिंबित और पुनः पुष्टि प्रदान करता आ रहा है। उन्होंने इस बात पर भी प्रकाश डाला कि विभाग कैसे विभिन्न अभूतपूर्व तरीकों से परिसर में छात्रों को सलाह देने सहित विभागीय प्रणाली में पूर्व छात्रों को जोड़कर उनकी ताकत का लाभ उठाने पर विचार करता आ रहा है।

Chairperson
University School of Management
Kurukshetra University,
KURUKSHETRA-136119.

पूर्व छात्र किसी भी शैक्षणिक संस्थान की अमूल्य धरोहर : प्रो. सोमनाथ सचदेवा



पूर्व छात्र व मुख्यअतिथि स्मारिका पुस्तिका का विमोचन करते। संवाद

संवाद न्यूज एजेंसी

कुरुक्षेत्र। किसी भी शैक्षणिक संस्थान के पूर्व छात्र उसकी अमूल्य धरोहर होते हैं, जिससे शैक्षणिक संस्थान की पहचान बनती है। जीवन में प्रगति के लिए बुनियादी आधार पर एक मजबूत नींव की आवश्यकता होती है, जिसके फलस्वरूप पूर्व छात्र शैक्षणिक संस्थान की नींव को मजबूती और आधार प्रदान करने का कार्य करते हैं।

उक्त विचार शनिवार को केयू के कुलपति प्रो. सोमनाथ सचदेवा ने ऑडिटोरियम हॉल में यूनिवर्सिटी स्कूल ऑफ मैनेजमेंट की स्थापना के 50वें स्वर्ण जयंती वर्ष के उद्घाटन के दौरान बतौर मुख्य अतिथि कहे। प्रो. सचदेवा

ने कहा कि पूर्व छात्र ही शैक्षणिक संस्थान की विशिष्ट पहचान होते हैं। इसलिए पूर्व छात्रों के अनुभवों के द्वारा विश्वविद्यालय को प्रगति के पथ पर अग्रसर किया जा सकता है।

उन्होंने सभी पूर्व छात्रों से विश्वविद्यालय की बेहतरी एवं मजबूती के लिए मिलकर कार्य करने का आह्वान किया। यूनिवर्सिटी स्कूल ऑफ मैनेजमेंट की विभागाध्यक्ष डॉ. निर्मला चौधरी ने विभाग की पचास वर्ष की उपलब्धियों के बारे में विस्तार से बताते हुए भविष्य के लिए एक दृष्टिकोण प्रस्तुत किया, जो कि विभाग के प्रयासों को प्रतिबिंबित और पुनः पुष्टि प्रदान करता है। इस दौर पूर्व छात्रों को सम्मानित करते हुए एक स्मारिका का विमोचन भी किया गया।

Chairperson
University School of Management
Kurukshetra University,
KURUKSHETRA-136119.

पूर्व छात्र किसी भी शैक्षणिक संस्थान की अमूल्य धरोहर : प्रो. सोमनाथ सचदेवा

कुवि के यूनिवर्सिटी स्कूल ऑफ मैनेजमेंट की स्थापना के गौरवमयी 50वर्षों को लेकर 'सारूप्य स्वर्ण जयंती पूर्व छात्र मिलन' कार्यक्रम आयोजित

कुरुक्षेत्र (डी.आर.मटनागर) : कुरुक्षेत्र विश्वविद्यालय के कुलपति प्रोफेसर सोमनाथ सचदेवा ने कहा कि किसी भी किसी भी शैक्षणिक संस्थान के पूर्व छात्र उसकी अमूल्य धरोहर होते हैं जिससे शैक्षणिक संस्थान की पहचान बनती है। उन्होंने कहा कि जीवन में प्रगति के लिए बुनियादी आधार पर एक मजबूत नींव की आवश्यकता होती है जिसके फलस्वरूप पूर्व छात्र शैक्षणिक संस्थान की नींव को मजबूती एवं आधार प्रदान करने का कार्य करते हैं। वे शनिवार को कुरुक्षेत्र विश्वविद्यालय के ऑडिटोरियम हॉल में कुवि के यूनिवर्सिटी स्कूल ऑफ मैनेजमेंट की स्थापना के 50वर्षों के गौरव और विरासत को चिह्नित करने के लिए आयोजित सारूप्य स्वर्ण जयंती पूर्व छात्र मिलन कार्यक्रम के उद्घाटन अवसर पर बतौर मुख्यातिथि बोल रहे थे। इस अवसर पर कुवि कुलपति प्रोफेसर सोमनाथ सचदेवा ने कहा कि पूर्व छात्र ही शैक्षणिक संस्थान की विशिष्ट पहचान होते हैं। इसलिए पूर्व छात्रों के अनुभवों के द्वारा विश्वविद्यालय की प्रगति के पथ पर अग्रसर किया जाना

चाहिए। उन्होंने सभी पूर्व छात्रों से विश्वविद्यालय की बेहतरी एवं मजबूती के लिए मिलकर कार्य करने का आह्वान भी किया। इस अवसर पर यूएस, यूके, जर्मनी, आदि सहित भारत व दुनिया भर से 700 से अधिक पूर्व छात्रों ने इस भव्य आयोजन में भाग लिया, जिसने उन्हें अपनी रबीनिंग स्मृति रेखाओं को याद दिलाने में सक्षम बनाया। कार्यक्रम में पूर्व छात्र अमिताभ शर्मा, ने विभाग की मेधावी और वरिष्ठ छात्रों के लिए छात्रवृत्ति की शुरुआत की। सुधीर मुनिया और मनोहर सिंह (1979-81 बैच) ने विभाग के बुनियादी ढांचे के विकास के लिए राशिदान स्वरूप दी। शारदा, बंसल, और कई अन्य लोगों ने सेवानिवृत्त शिक्षकों और छात्रों को उपहार भेंटस्वरूप दिए। स्वर्ण जयंती शोभायात्रा के बाद, यूनिवर्सिटी स्कूल ऑफ मैनेजमेंट की विभागाध्यक्ष, डॉ. निर्मला चौधरी ने विभाग की उपलब्धियों और इसके भविष्य के लिए एक दृष्टिकोण प्रस्तुत किया, जो विभाग के प्रयासों को प्रतिबिंबित और पुनः पुष्टि प्रदान करता आ रहा है। उन्होंने इस

बात पर भी प्रकाश डाला कि विभाग कैसे विभिन्न अमूल्यपूर्व तरीकों से परिसर में छात्रों को सलाह देने सहित विभागीय प्रणाली में पूर्व छात्रों को जोड़कर उनकी ताकत का लाभ उठाने पर विचार करता आ रहा है। कार्यक्रम में सभी पूर्व छात्रों को सम्मानित किया गया तथा इसके साथ ही पूर्व छात्रों की स्मारिका के विमोचन और विभाग के पहले बैच द्वारा कंक काटने की रस्म के साथ यह दिन, और भी खास बन गया। इस मौके पर प्रो. रमेश चंद्र प्रो. सुशील शर्मा, प्रो. अनिल मित्तल, प्रो. सिद्धार्थ भारद्वाज, डॉ. सलोनी पी. दीवान, डॉ. अजय सोलखे, डॉ. विवेक कुमार, डॉ. भंवर सिंह, और अन्य गणमान्य अतिथियों सहित सभी संकाय सदस्य मौजूद रहे।

कार्यक्रम में डॉ. हरविन्द्र राणा ने बी बम लहरी पर विशेष प्रस्तुति दर्शकों मंत्रमुग्ध हो झूमने लगे कुवि यूनिवर्सिटी स्कूल ऑफ मैनेजमेंट की स्थापना के 50वर्षों के गौरवमयी इतिहास को लेकर आयोजित सारूप्य स्वर्ण जयंती पूर्व छात्र मिलन कार्यक्रम में हरियाणा कला परिषद के सौजन्य से कुरुक्षेत्र विश्वविद्यालय के युवा एवं सांस्कृतिक कार्यक्रम विभाग के डॉ. हरविन्द्र सिंह राणा ने बम लहरी भजन पर दमदार प्रस्तुति देकर ऑडिटोरियम हॉल में मौजूद सभी दर्शकों को झूमने पर मजबूर कर दिया। इस अवसर पर कुवि कुलपति प्रोफेसर सोमनाथ सचदेवा ने इस प्रस्तुति की सराहना की। केयू यूएसएम की अध्यक्ष प्रो. निर्मला चौधरी ने भी पूर्व छात्रों के समक्ष दी गई इस प्रस्तुति के लिए डॉ. हरविन्द्र राणा का आभार व्यक्त किया।



Chaitan
University School of Management
Kurukshetra University,
KURUKSHETRA-136119.

इ को
खेड़ी
या।
ने
कमले
ला में
ने को
शहर
: छल
: सिंह
ले के
हां से

केयू के यूनिवर्सिटी स्कूल ऑफ मैनेजमेंट ने मनाया स्वर्ण जयंती पूर्व छात्र मिलन समारोह जीवन में प्रगति के लिए मजबूत नींव की आवश्यकता होती है : सोमनाथ सचदेवा

भास्कर न्यूज़ | कुरुक्षेत्र

1 शुक
अमर,
से 15
भाईसी
केयू),
स्वीक
: लि
या में
परिभा
सहित

कुरुक्षेत्र विश्वविद्यालय के ऑडिटोरियम हॉल में केयू के यूनिवर्सिटी स्कूल ऑफ मैनेजमेंट की स्थापना के 50 साल पूरे होने पर स्वर्ण जयंती पूर्व छात्र मिलन समारोह आयोजित किया गया। इसमें मुख्यअतिथि केयू कुलपति प्रो. सोमनाथ सचदेवा रहे। प्रो. सचदेवा ने कहा कि किन्हीं भी शैक्षणिक संस्थान के पूर्व छात्र उसकी अमूल्य धरोहर होते हैं, जिसमें शैक्षणिक संस्थान की पहचान बनती है। उन्होंने कहा कि जीवन में प्रगति के लिए बुनियादी आधार पर एक मजबूत नींव की आवश्यकता होती है। इसके फलस्वरूप पूर्व छात्र शैक्षणिक संस्थान की नींव को

मजबूती एवं आधार प्रदान करते हैं। इस अवसर पर यूएमए, एफके, जर्मनी सहित दुनियाभर से 700 से अधिक पूर्व छात्र शामिल हुए। पूर्व छात्र अमिताभ शर्मा ने विभाग की मेधावी और खचित छात्राओं के लिए छात्रकृति की शुरुआत की। सुधीर गुलिया और मनोहर सिंह (1979-81 बैच) ने विभाग के बुनियादी ढांचे के विकास के लिए राशि दान स्वरूप दी। शरदा बंसल और कई अन्य लोगों ने सेवानिवृत्त शिक्षकों और छात्रों को उपहार दिए। स्वर्ण जयंती रोभायात्रा के बाद यूनिवर्सिटी स्कूल ऑफ मैनेजमेंट की विभागाध्यक्ष प्रो. निर्मला चौधरी ने विभाग की उपलब्धियों और इसके भविष्य के लिए दृष्टिकोण प्रस्तुत



कुरुक्षेत्र | केयू के स्कूल ऑफ मैनेजमेंट के 50 वें स्थापना दिवस समारोह में छात्रकृति के लिए केयू कुलपति को चेक देते पूर्व छात्र।

किया। कार्यक्रम में सभी पूर्व छात्रों को सम्मानित किया और पूर्व छात्रों की स्मृतिका का विमोचन किया गया। इस मौके पर प्रो. रमेश चंद, प्रो. सुरजीत शर्मा, प्रो. अर्जुन मिश्र, प्रो. सिद्धार्थ भारद्वाज, डॉ. सलोनी टीकान, डॉ. अजय सोलंकी, डॉ. विवेक कुमार और डॉ. भवर सिंह मौजूद रहे। डॉ. हरविंद राणा ने दी बम

लहरी की प्रस्तुति: केयू के यूनिवर्सिटी स्कूल ऑफ मैनेजमेंट की स्थापना के 50 वर्षों के गौरवमयी इतिहास को लेकर आयोजित स्वर्ण जयंती पूर्व छात्र मिलन कार्यक्रम में केयू के युवा एवं सांस्कृतिक कार्यक्रम विभाग के डॉ. हरविंद राणा ने बम लहरी भजन पर प्रस्तुति दी। इस प्रस्तुति पर सभी पूर्व छात्र भी झूमने लगे।

Chairperson
University School of Management
Kurukshestra University,
KURUKSHETRA-136119.

हरियाणा कला परिषद की ओर से कलाकारों ने मचाया लोकनृत्यों से धमाल

कुरुक्षेत्र, 4 मार्च
: कुरुक्षेत्र विश्वविद्यालय के स्कूल ऑफ मैनेजमेंट ने 50वां जन्मदिन कुवि में मनाया। अंतर्राष्ट्रीय ख्याति प्राप्त लोक गायक हरविंद्र राणा के बम लहरी से धूम मचाई।

कुरुक्षेत्र विश्वविद्यालय के स्कूल ऑफ मैनेजमेंट के 1973 से अब तक के विद्यार्थियों ने कार्यक्रम में भाग लिया।

कार्यक्रम के मुख्यातिथि के रूप में प्रो. सोमनाथ सचदेवा कुलपति कुरुक्षेत्र विश्वविद्यालय ने शिरकत की। प्रो. सुदेश छिकारा

कुलपति भगत सिंह महिला विश्वविद्यालय भी उपस्थिति रहीं।

हरियाणा कला परिषद के सौजन्य से इस कार्यक्रम में मुख्य रूप से सांस्कृतिक कार्यक्रम का आयोजन किया गया, जिसमें हरविंद्र राणा ने बम लहरी के माध्यम से हरियाणवी संस्कृति का परिचय दिया।

सभी विद्यार्थियों ने गीत के साथ साथ मस्ती में नृत्य भी किया। प्रोफेसर निर्मला चौधरी स्कूल ऑफ मैनेजमेंट की चेयरपर्सन ने हरियाणा कला परिषद को इस कार्यक्रम के लिए उनका विशेष आभार व्यक्त किया।



मंच पर प्रस्तुति देते छात्र।

Chairperson
University School of Management
Kurukshetra University,
KURUKSHETRA-136119.

UNIVERSITY SCHOOL OF MANAGEMENT

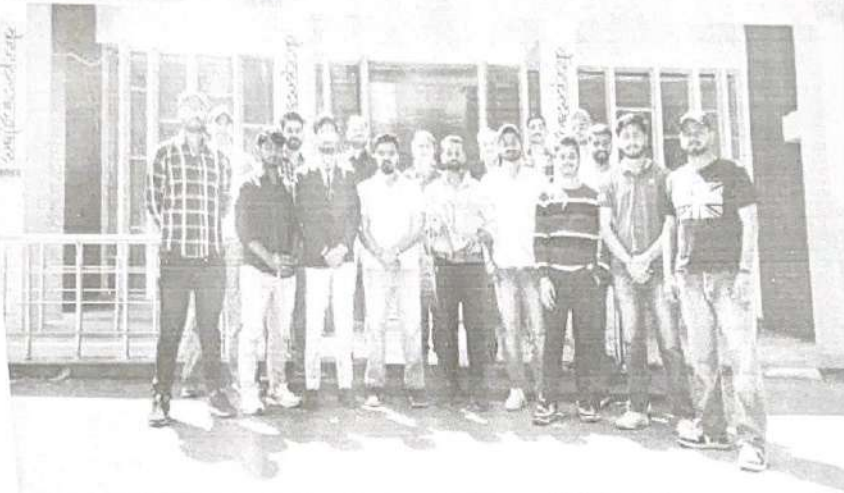

Chairperson
University School of Management
Kurukshetra University,
KURUKSHETRA-136119.

आत्मदीपः भव

BE YOUR OWN LIGHT

दीपमंगलम् 2023

**UNIVERSITY SCHOOL OF MANAGEMENT
KURUKSHETRA UNIVERSITY KURUKSHETRA**

is organising

**POSTER MAKING COMPETITION
DIYA DECORATION COMPETITION**

Tuesday | 7th November, 2023

**RAMP WALK (TRADITIONAL)
DANCE COMPETITION**

Wednesday | 8th November, 2023

Dance theme: Traditional

VENUE - USM, KUK



* Last date for registration for the competitions is 6th November till 12 Noon. For any query, please contact: 9729087393 (Manisha),

*The participants for dance competition are required to share their one minute dance video. 9306554339 (Kartik), 8708130700 (Ankur)

****Attractive prizes are waiting for you.****

Chairperson
University School of Management
Kurukshetra University,
KURUKSHETRA-136119.



University School Of Management



Presents

DIWALI MELA 2022

JOIN US AS WE COME TOGETHER TO
BLOOM A FLOWERPOT OF HAPPINESS!

Time: 10AM

Date: 20th October 2022.

VENUE:

UNIVERSITY SCHOOL OF MANAGEMENT,
KURUKSHETRA UNIVERSITY,
KURUKSHETRA

For Any Queries:

Janvi (8708112922)

Pooja (7496830213)

Saurav (7015949806)

Anupama (7404088669)



Chairperson
University School of Management
Kurukshetra University,
KURUKSHETRA-136119.



Competitions:



- 1) Diya Decoration
- 2) Best Out Of Waste
- 3) On The Spot Painting

*Attractive Cash prizes will be given to the Winners.

Opportunities:

- 1) Food Stall
- 2) Game Stall
- 3) Business Stall



SCAN QR CODE FOR
REGISTRATION



Chairperson
University School of Management
Kurukshetra University,
KURUKSHETRA-136119.



University School Of Management, Kurukshetra University Kurukshetra

Mar 18 · 🌐

संवाद न्यूज एजेंसी

कुरुक्षेत्र। इंटर डिपार्टमेंट की क्रिकेट प्रतियोगिता में यूनिवर्सिटी स्कूल ऑफ मैनेजमेंट विभाग ने क्रिकेट प्रतियोगिता जीती वहीं डिपार्टमेंट ऑफ होटल एंड टूरिज्म मैनेजमेंट की टीम दूसरे स्थान पर रही।

इसके साथ-साथ विभागों में अलग-अलग खेल प्रतियोगिता का आयोजन किया गया था, जिसमें लेमन स्पून रेस, रिले रेस, बैडमिंटन, वॉलीबॉल, पंजे बाजी, सक रेस, रस्साकशी के विजेता प्रतिभागियों को निदेशक प्रो. मोहनन्दर चंद द्वारा और खेल के मुख्य प्रयोजक

विजेताओं को एसबीआई लाइफ की तरफ से वितरित किए गए पुरस्कार

किये गए।

खेल की कोऑर्डिनेटर सहायक प्रोफेसर मेघा गुप्ता, डॉक्टर अंकुश नंबरदार, डॉक्टर सुरजीत और डॉक्टर दिनेश धनखड़ द्वारा आए हुए मेहमानों का स्वागत किया गया।

इस इस मौके पर विभाग के सहायक प्रोफेसर डॉ. महेश कुमार, डॉ मनजीत सिंह, डॉक्टर संदीप धनखड़, डॉ गौरव सिंह, शेफ अमित कुमार, डॉ. राजीव सिंह और डॉ राहुल गर्ग, डॉ. सुनील, डॉ



Chairperson
University School of Management
Kurukshetra University,
KURUKSHETRA-136119.

पूर्व छात्र शैक्षणिक संस्थान की पहचान: सचदेवा

अभारण संकल्पना कुटुम्ब : कुटुम्ब विभागाध्यक्ष के युनिवर्सिटी स्कूल आफ मैनेजमेंट में शनिवार को स्वयंसेवकों के 50 वर्ष की लंकरा संस्था स्वर्ण जयंती पूर्व छात्र मिलन कार्यक्रम हुआ। कार्यक्रम में अतिरिक्त मुख्याधीन कुलपति प्रो. सोमनाथ सचदेवा ने कहा कि किसी भी शैक्षणिक संस्थान के पूर्व छात्र उसको अत्यन्त धरोहर होते हैं। इनसे शैक्षणिक संस्थान की पहचान बनती है।

उन्होंने कहा कि जीवन में प्रगति के लिए बुनियादी आधार पर एक मजबूत नींव की आवश्यकता होती है। यही पूर्व छात्र शैक्षणिक संस्थान की नींव को मजबूत एवं आधार प्रदान करने का कार्य करते हैं। उन्होंने कहा कि पूर्व छात्र ही शैक्षणिक संस्थान को विभिन्न पहचान होते हैं। इसलिए पूर्व छात्रों के अनुभवों के द्वारा बिंबि को प्रगति के पथ पर अग्रसर किया जाना



युनिवर्सिटी स्कूल आफ मैनेजमेंट की स्थापना दिवस पर कुलपति प्रो. सोमनाथ सचदेवा को पूर्व छात्र परसंस्थान के लिए निमंत्रण द्वाारा स्वर्ण जयंती पूर्व छात्रों ने सौंपा।

चाहिए। उन्होंने सभी पूर्व छात्रों से बिंबि को बेहतर एवं मजबूत के लिए मिलकर कार्य करने का आह्वान भी किया। इस मौके पर पूर्व छात्रों ने भी कुवि पूर्व छात्र परसंस्थान को करीब 20 लाख रुपये की राशि दान की। इस कार्यक्रम में यूएमए

युनाइटेड किंगडम व जर्मनी देहा धर्म से 700 के करीब पूर्व छात्रों ने हिस्सा लिया।

कार्यक्रम में पूर्व छात्र अमित धर्म ने विभाग की मेधावी और बेहत छात्रों के लिए छात्रवृत्ति को शुरूआत करने की घोषणा की। सुधोर

गुलिय और मन्नेहर सिंह (1973-81 बैच) ने विभाग के युनिवर्सिटी छात्रों के विकास के लिए राशि दान स्वयंसेवक की। शहरद, बंसल सहित कई अन्य लोगों ने सेवानिवृत्त शिक्षकों और बिद्यार्थियों को उपहार भेंट किए। स्वर्ण जयंती शोभायात्रा के बाद युनिवर्सिटी स्कूल आफ मैनेजमेंट का विभागाध्यक्ष डा. निर्मला चौधरी ने विभाग की उपलब्धियों और इसके भविष्य के लिए एक दृष्टिकोण प्रस्तुत किया। कार्यक्रम में सभी पूर्व छात्रों को अंग वस्त्र प्रदान कर सम्मानित किया गया। इसके साथ ही पूर्व छात्रों को स्मारिका का विमोचन किया गया और केट काटने का रस्म भी अत्र की गई। कार्यक्रम में डा. हर्षवेंद्र राणा ने बम लहरों पर विशेष प्रस्तुति दी। इस मौके पर प्रो. रमेश चंद्र, प्रो. सुरेश शर्मा, प्रो. अनिल मिश्र, प्रो. सिद्धार्थ भारद्वाज, डा. सलीम मो. टोबान, डा. अजय खेल्खे, डा. विवेक कुमार मौजूद रहे।

Chairperson
University School of Management
Kurukshetra University,
KURUKSHETRA-136419.



University School Of Management, Kurukshetra University Kurukshetra

Nov 16, 2023 · 🌐

Deepamangalam 2023

⚙️ · Rate this translation



Chairperson
University School of Management
Kurukshetra University,
KURUKSHETRA-136119.



University School Of Management, Kurukshetra University Kurukshetra

Nov 13, 2023 · 🌐

Deepamangalam 2023

🌟 · Rate this translation



Chairperson
University School of Management
Kurukshetra University,
KURUKSHETRA-136119.

Deepamangalam 2023

⚙️ • Rate this translation

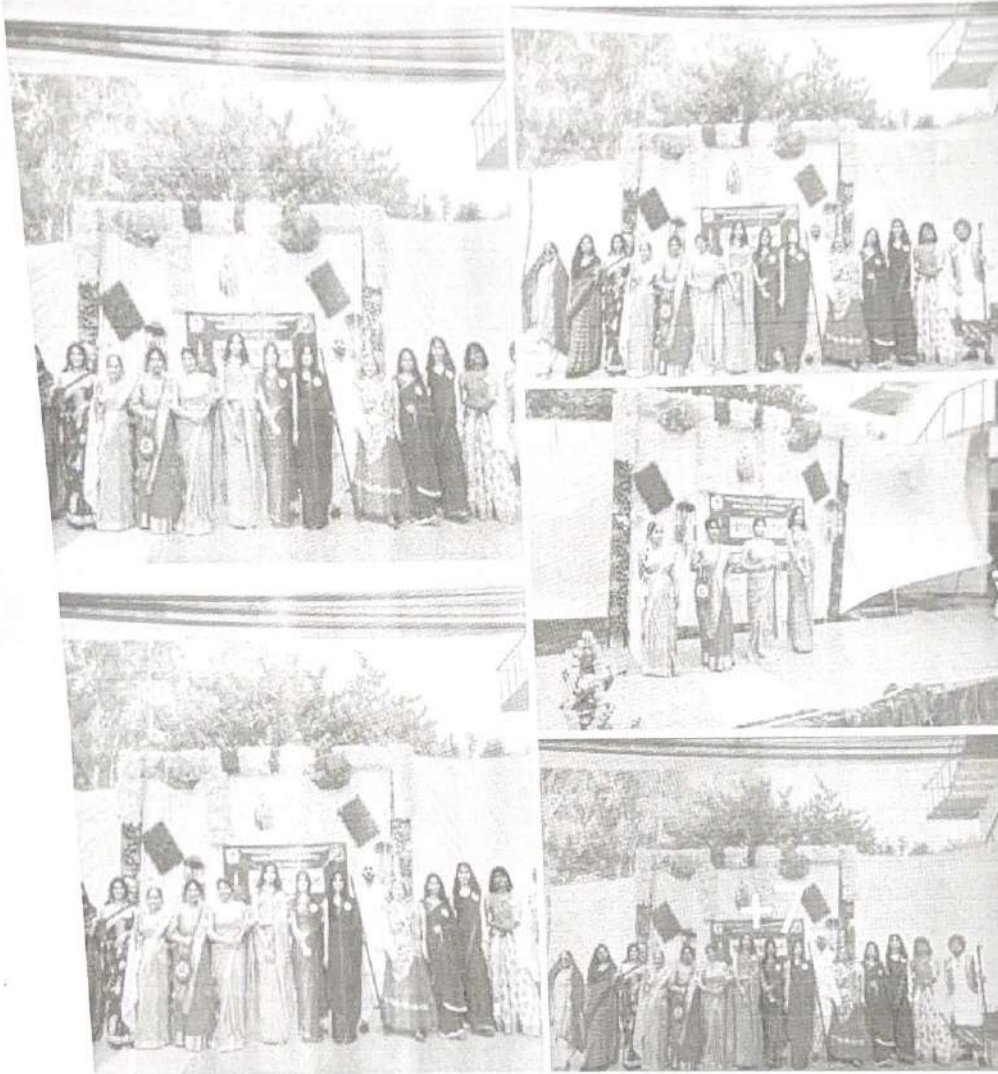

Chairperson
University School of Management
Kurukshetra University,
KURUKSHETRA-136119.



University School Of Management, Kurukshetra University Kurukshetra

Jul 25, 2022 · 🌐

Students of University School of Management Kurukshetra University Kurukshetra organized a cultural and educational session inc... See more

⚙️ • Rate this translation



Chairperson
University School of Management
Kurukshetra University,
KURUKSHETRA - 136119.



Chairperson
University School of Management
Kurukshetra University,
KURUKSHETRA-136119.

**DEPARTMENT OF GEOGRAPHY,
KURUKSHETRA UNIVERSITY KURUKSHETRA**
(Established by State Legislature Act-XII of 1956)
(**'A+' Grade, NAAC Accredited**)

Date: 17.11.2022

Prof. S.P. Kaushik
Chairman, Department of Geography.

NOTICE

Following teachers shall maintain the discipline in the Freshers' Welcome party of student at the Community Centre, Kurukshetra University, Kurukshetra on November 19, 2022.

1. Dr. Anju Gupta
2. Dr. Ravinder

Chairman
Chairperson
Department of Geography
Kurukshetra University,
KURUKSHETRA-136119.

**DEPARTMENT OF GEOGRAPHY,
KURUKSHETRA UNIVERSITY KURUKSHETRA**
(Established by State Legislature Act-XII of 1956)
(**'A+' Grade, NAAC Accredited**)

Date: 26.09.2023

Prof. S.P. Kaushik
Chairman, Department of Geography.

NOTICE

Following teachers shall maintain the discipline in the Freshers' Welcome party of student at the Community Centre, Kurukshetra University, Kurukshetra on September 26, 2023.

1. Dr. Anju Gupta
2. Dr. Ravinder

Chairman,
Chairperson
Department of Geography
Kurukshetra University,
KURUKSHETRA-136119

**DEPARTMENT OF GEOGRAPHY,
KURUKSHETRA UNIVERSITY KURUKSHETRA**
(Established by State Legislature Act-XII of 1956)
('A+' Grade, NAAC Accredited)

Dated: 10.05.2023

Prof. S.P. Kaushik
Chairman, Department of Geography.

Notice

Farewell party of the MSc. Final year students, session 2022-23 will be held on 10.05.2023 at 9.00 a.m. onwards. The venue of the party is community centre, KUK. All the students and staff members are invited to attend the party. Dr Suman Chauhan, Dr Anju Gupta and Dr Ravinder shall remain on duty to maintain discipline at the venue.

Chairman,
Department of Geography
Kurukshetra University,
KURUKSHETRA-136119.







A Painting Competition was held at Institute of Pharmaceutical Sciences, Kurukshetra University, Kurukshetra under the theme of **India's G20 presidency "Vasudhaiva Kutumbakam"** or One Earth One Family One Future closely ties with **LiFE (Life Style for Environment)** on 24th February, 2023. Students participated very enthusiastically in this event and they beautifully explained their views about India's G20 presidency "Vasudhaiva Kutumbakam" via their paintings. Prof Kiran Singh, Director of Institute of Pharmaceutical Sciences, Kurukshetra University, Kurukshetra graced the occasion and congratulated participants of the event. She also explained the role of India in G20 programme. Dr. Lalita, Assistant Professor, Institute of Pharmaceutical Sciences, Kurukshetra University, Kurukshetra and Dr. Manjusha, Assistant Professor, Institute of Pharmaceutical Sciences, Kurukshetra University, Kurukshetra have organized this event. Dr. Kamal and Ms. Anju Goyal from the institute were invited as judges for evaluation. Monty (B.Pharmacy 4th Semester) won the 1st Position, Vanshika (B.Pharmacy 4th Semester) won 2nd position and Samriti (B.Pharmacy 4th Semester) won 3rd position. In the Consolation Prizes Arzoo Saini (B.Pharmacy 1st Semester) and Saksham (B.Pharmacy 4th Semester) were nominated as winners.

INSTITUTE OF PHARMACEUTICAL SCIENCES
KURUKSHETRA UNIVERSITY KURUKSHETRA
(Established by the State Legislature Act XII of 1956)
("A+" Grade NAAC Accredited)

No. IPS/22/

Dated : _____

Notice

All the students of B.Pharm, M.Pharm and Research Scholars are hereby informed that a Painting Competition, under the theme of **India's G20 presidency "Vasudhaiva Kutumbakam"** or **One Earth One Family One Future** closely ties with **LiFE (Life Style for Environment)** with focus on sustainable and environment friendly life styles, will be held in the Institute of Pharmaceutical Sciences, Kurukshetra University on 24th February, 2023 at 10.00 am-12 pm. The interested students can give their name to Dr. Lalita upto 20th February, 2023.

Kiran
16/02/23
DIRECTOR

Lalita
16/2/2023

Dr. Lalita. Convenor.

Manjusha
16/2/23

Dr. Manjusha



REDMI NOTE 9 PRO MAX
AI QUAD CAMERA



REDMI NOTE 9 PRO MAX
AI QUAD CAMERA



5.3.3 cultural events



DEPARTMENT OF ENGLISH
KURUKSHETRA UNIVERSITY KURUKSHETRA
(Established by the State Legislature Act XII of 1956)
(‘A+’ Grade, NAAC Accredited)

Activity Report: Cricket Match Organized by the Department of English

Date: 18.04.2023

Objective:

The objective of organizing the cricket match was to promote camaraderie, sportsmanship, and physical well-being among students enrolled in the Department of English. This initiative aimed to provide students with a platform to engage in healthy competition, foster teamwork, and create memorable experiences outside the classroom environment.

Participants:

The cricket match witnessed enthusiastic participation from students affiliated with the Department of English. Students actively took part in the event, showcasing their sporting skills and team spirit.

Activities Undertaken:

Planning and Coordination:

- A planning committee comprising faculty members and student representatives was formed to oversee the organization and execution of the cricket match.
- The committee finalized the date, venue and rules for the event, ensuring smooth coordination and participation.

Team Formation:

- Students were encouraged to form teams consisting of 11 players.
- Each team appointed a captain responsible for strategizing, leading, and coordinating team activities.

Promotion and Registration:

- Registration forms were circulated, and teams were required to register their participation within a specified deadline.

Cricket Match:

On the scheduled day, teams gathered at the designated cricket ground with high spirits and energy.

The match commenced with an opening ceremony, including a brief introduction of teams and officials, followed by the national anthem.

The cricket match was played with enthusiasm, intensity, and fair play, showcasing the sporting talent and competitive spirit of the participants.

Spectators, including faculty members, staff, and fellow students, cheered enthusiastically, adding to the vibrant atmosphere of the event.

Award Ceremony:

At the conclusion of the match, an award ceremony was held to felicitate the winning team and individual players for their outstanding performance.

Trophy was presented to the deserving team and players as a token of appreciation for their participation and sportsmanship.

Outcome:

The cricket match served as a memorable and engaging experience for students associated with the Department of English. It provided an opportunity for students to unwind, socialize, and showcase their talent beyond academic pursuits. The event fostered a sense of camaraderie, unity, and mutual respect among participants, contributing to a vibrant and inclusive campus culture.

Conclusion:

The successful organization of the cricket match underscored the Department of English's commitment to holistic education and student development. It highlighted the importance of extracurricular activities in promoting physical fitness, teamwork, and interpersonal skills among students. Moving forward, similar sporting events and activities will be organized to further enrich the student experience and strengthen community bonds within the department.



Chairperson

DEPARTMENT OF ENGLISH
KURUKSHETRA UNIVERSITY KURUKSHETRA
(Established by the State Legislature Act XII of 1956)
(‘A+’ Grade, NAAC Accredited)

Activity Report: Quiz on Shakespeare Organized by the Department of English

Date: 24.04.2023

Objective: The Department of English organized a Quiz on Shakespeare to enhance students' understanding and appreciation of the renowned playwright's works and contributions to literature. The quiz aimed to foster a competitive yet educational atmosphere among participants.

Participants: The quiz saw enthusiastic participation from undergraduate and postgraduate students majoring in English Literature. A total of 60 students formed 15 teams, each eager to showcase their knowledge of Shakespearean plays, sonnets, and literary themes.

Format: The quiz consisted of 3 rounds, featuring a blend of multiple-choice questions, identification of quotes, character analysis, and thematic understanding. Questions were designed to test both factual knowledge and critical thinking skills related to Shakespeare's works.

Execution: The event commenced with an introduction by Dr. Upasana highlighting the significance of Shakespeare in English literature and the relevance of his works in contemporary contexts. Teams were then seated, and the quizmaster Ms. Harwinder Kaur guided participants through each round with engaging and thought-provoking questions.

Highlights:

- **Interactive Rounds:** Participants actively engaged in discussions and debates over interpretations of Shakespearean texts.
- **Competitive Spirit:** Teams displayed impressive teamwork and competitive spirit, adding excitement to the event.
- **Learning Opportunities:** The quiz not only tested knowledge but also served as a platform for learning new insights and perspectives on Shakespeare's writings.

Conclusion: The Quiz on Shakespeare organized by the Department of English was a resounding success, achieving its goal of promoting scholarly engagement with Shakespeare's works. Participants left with enhanced appreciation and enthusiasm for further exploration of Shakespearean literature.

Future Prospects: Building on this success, the Department plans to continue organizing such intellectual competitions to nurture students' interest in literature and critical analysis. Future events will explore different literary themes and authors, ensuring a well-rounded academic experience for all participants.



Chairperson

DEPARTMENT OF ENGLISH
KURUKSHETRA UNIVERSITY KURUKSHETRA

(Established by the State Legislature Act XII of 1956)

('A+' Grade, NAAC Accredited)

Activity Report: Health Check Up Camp Organized by NSO in the Department of English

Date: 24.04.2023

Objective: The primary objective of organizing the Health Check-Up Camp at the Department of English was to promote the health and well-being of students and faculty members through comprehensive medical screenings and consultations. NSO, a dedicated social service NGO, facilitated this initiative to ensure that participants could avail themselves of essential healthcare services conveniently within their educational environment.

Activities Undertaken:

1. Registration and Patient Management:

- Upon arrival, participants registered themselves with volunteers from NSO.
- Each participant received a unique identification number for efficient tracking throughout the camp.

2. Medical Screening:

- A team of qualified healthcare professionals conducted a series of medical tests and screenings.
- Tests included blood pressure monitoring, BMI calculation, and sugar monitoring.

3. Consultations:

- Participants had the opportunity to consult with doctors and healthcare specialists regarding their individual health concerns.
- Personalized advice on diet, exercise, and preventive healthcare measures was provided.

4. Awareness Sessions:

- Informational pamphlets and brochures were distributed to enhance health awareness among attendees.

5. Referrals and Follow-Up:

- Participants requiring further medical attention or specialized care were referred to appropriate healthcare facilities.
- Follow-up consultations and recommendations were provided to ensure continuity of care.

Outcome: The Health Check-Up Camp witnessed active participation from both students and faculty members of the Department of English. Key outcomes include:

- **Health Concerns Identified:** Common issues such as poor posture, High Blood Pressure and early signs of hypertension were identified and addressed promptly.
- **Feedback and Satisfaction:** Feedback from participants indicated high satisfaction with the organization and quality of healthcare services provided by NSO.

Conclusion: The Health Check-Up Camp organized by NSO at the Department of English was successful in achieving its objectives of promoting health awareness and providing essential medical screenings to students and faculty members. The collaboration between NSO and the

educational institute facilitated a seamless experience for participants, contributing positively to their overall well-being. We express our gratitude to NSO for their commitment to community health and look forward to future collaborative initiatives.

A handwritten signature in blue ink that reads "Rashmi Vane". The signature is written in a cursive style with a large initial 'R'.

Chairperson

Department of English







 GPS Map Camera

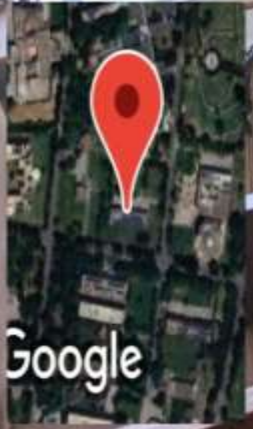

Google

Thanesar, Haryana, India

XR57+VWR, Kurukshetra University, Thanesar, Haryana 136119,
India

Lat 29.959735°

Long 76.814854°

09/05/23 10:08 AM GMT +05:30













 **GPS Map Camera**

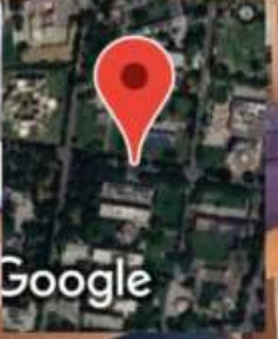

Google

Thanesar, Haryana, India

XR57+MQ7, Kurukshetra University, Thanesar, Haryana 136119, India

Lat 29.959334°

Long 76.814555°

28/03/23 11:34 AM GMT +05:30



DEPARTMENT OF ENGLISH
OPERATIONAL RESEARCH

GPS Map Camera

Thanesar, Haryana, India
XR57+VRX, Kurukshetra University, Thanesar, Haryana 136119,
India
Lat 29.959817°
Long 76.814586°
07/04/23 10:06 AM GMT +05:30

Google



 GPS Map Camera

Thanesar, Haryana, India
XR57+VWR, Kurukshetra University, Thanesar, Haryana 136119,
India
Lat 29.959714°
Long 76.814883°
09/05/23 10:11 AM GMT +05:30





 GPS Map Camera

Thanesar, Haryana, India

XR38+XPF, Kurukshetra University, Thanesar, Haryana 136119,
India

Lat 29.954808°

Long 76.816412°

18/04/23 10:14 AM GMT +05:30

Google

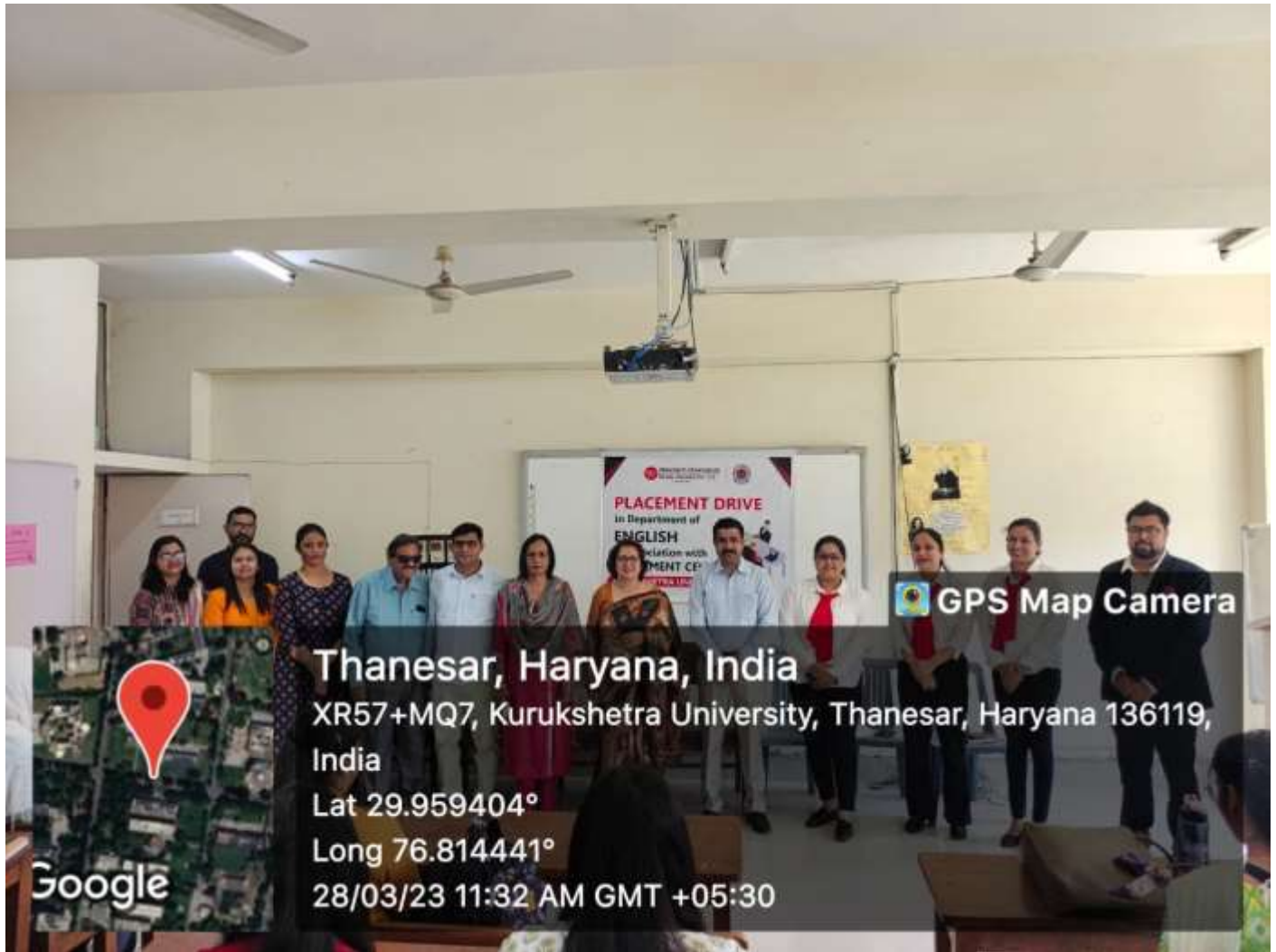

Thanesar, Haryana, India

XR57+MQ7, Kurukshetra University, Thanesar, Haryana 136119, India

Lat 29.959404°

Long 76.814441°

28/03/23 11:32 AM GMT +05:30





University Grants Commission
HUMAN RESOURCE DEVELOPMENT CENTRE

Sr. No. 1126

**KURUKSHETRA UNIVERSITY,
KURUKSHETRA**

(Established by the State Legislature Act XII of 1956)
(A+ Grade, NAAC Accredited)



UGC-SPONSORED ONLINE REFRESHER COURSE

CERTIFICATE OF PARTICIPATION

This is to certify that Dr. (Ms) Aarti Sheokand, Assistant Professor, Department of Music and Dance, Kurukshetra University, Kurukshetra participated in the 2-Week Online Multidisciplinary Refresher Course in *Environment Challenges* on the theme "*Environmental Challenges : Issues and Remedies*" from 09-09-2022 to 22-09-2022 and obtained Grade 'A'.

(Dr. Smita Chaudhary)
Course Coordinator

(Prof. Manjula Chaudhary)
Director

(Dr. Sanjeev Sharma)
Registrar

Kurukshetra
Dated: 22-09-2022



Thanesar, Haryana, India
XR67+HW6 Park (University College), Kurukshetra University,
Thanesar, Haryana 136119, India
Lat 29.961131°
Long 76.814748°
14/09/22 11:18 AM GMT +05:30

GPS Map Camera



**DEPARTMENT OF MATHEMATICS
KURUKSHETRA UNIVERSITY, KURUKSHETRA**

(Established By The State Legislature Act XII of 1956)
("A++" Grade NAAC Accredited)

Dated: 12.01.2023

NOTICE

This is to inform that all staff members & students please note that the Lohri Celebration will be held on 13.01.2023 at 12:00 noon. Please make it contingent to attend.

D
12/1/23

Deepu
12/1/2023

Brijanka

Pooja

Jyoti

Anurag

S. D.
Director
Ganit Parishad



DEPARTMENT OF MATHEMATICS
KURUKSHETRA UNIVERSITY, KURUKSHETRA

(Established By The State Legislature Act XII of 1956)
("A++" Grade NAAC Accredited)

Dated: 29.10.2023

NOTICE

Department of Mathematics is going to celebrate the Mehndi competition on 30.10.2023 at 01:00 pm in room no. 211. Therefore, all teachers and students please note.

Director
Ganit Parishad

Dr. Anil
Gupta
29/10/2023



(46)

Women's Studies Research Centre
Kurukshetra University, Kurukshetra – 136 119
(Established by the State Legislature Act XII of 1950)
("A" Grade, NAAC Accredited)

Prof. Anita Rani Dua
Director

No. WSRC/22/ 5023-
Dated : 27.2.2023

Subject: Celebration of International Women's Day on 2nd March 2023.

Dear Sir / Madam,

It gives me immense pleasure to inform you that the Women's Studies Research Centre is organizing a special session on the theme "Digital Education – Necessity and Caution" on 2nd March 2023 as a part of celebration of International Women's Day. The theme of the event is aligned with UN Women's theme for International Women's Day 2023. International Women's day is a worldwide celebration of women's historical, cultural, political and social accomplishments. The day also marks a call for action for accelerating gender equality and unbiased participation of women in each and every field and raise awareness in society. The session would be a platform to bring faculty and students together for discussion on issues related to digital education and necessity to be vigilant.

You and all the faculty members of your department are cordially invited to be the part of the celebration.

You are further requested to send two gender champions of your departments/institutes to attend the event.

PROGRAMME

Date	:	March 2 nd , 2023
Time	:	11.00 a.m. to 1.00 p.m.
Venue	:	Conference Room, WSRC, Kurukshetra.

With regards,

Anita Rani Dua
Gant Kishor
Sun

A
28/2/2023

Anita Rani Dua
Director
Women's Studies
U. KURUKSHETRA



DEPARTMENT OF MATHEMATICS
KURUKSHETRA UNIVERSITY, KURUKSHETRA
 (Established By The State Legislature Act XII of 1956)
 ("A+" Grade NAAC Accredited)

Dated 29.03.2023

NOTICE

Department of Mathematics is going to celebrate the Sports day on 03.04.2023 at 9:00 am onwards at University Sports Ground, KUK. All students and teachers are required to attend the same. No leave is allowed for teachers.

CHAIRMAN
 Deptt. of Mathematics
 K.U. KURUKSHETRA

 A

 Gupta

 Ratties

 A

 Jain

 D

 Dain

 R. P.



DEPARTMENT OF MATHEMATICS
KURUKSHETRA UNIVERSITY, KURUKSHETRA
(Established By The State Legislature Act XII of 1956)
("A+" Grade NAAC Accredited)

Dated 08.05.2023

NOTICE

Department of Mathematics is going to celebrate the Annual Function on 10.05.2023 from 9:00 am onwards at R.K. Sadan, KUK. All teachers and research scholars are required to attend the same and stay there till the closing of the function. No leave is allowed without prior permission of the Chairman.

CHAIRMAN: 
Deptt. of Mathematics
K.U. KURUKSHETRA





08/5/23

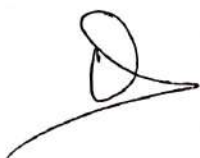



8/5/23



Sisra

8/5/23

Ratika

Komal

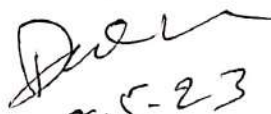
Sowab

8.5.23

DEPARTMENT OF MATHEMATICS
KURUKSHETRA UNIVERSITY, KURUKSHETRA
(Established By The State Legislature Act XII of 1956)
("A+" Grade NAAC Accredited)

NOTICE

The Rostrum: 2022-23 (Annual Public Speaking Competitions) Round-I will be held in the Department of Mathematics on 11-02-2023 at 12:30 PM. All Students and Teachers are required to make it attend.

Prof
Chairman
for  *Chairman*
Chairman
for  *Chairman*
Chairman

DEAN FACULTY OF ARTS & LANGUAGES
KURUKSHETRA UNIVERSITY KURUKSHETRA

(Established by the State Legislature Act XII of 1956)
("A+" Grade, NAAC Accredited)

Dated: 03.02.2023

**NOTICE: ROSTRUM: 2022-23 (ANNUAL PUBLIC SPEAKING COMPETITIONS)
ROUND-I**

All the students of Department of Foreign Languages and Dean Arts & Languages are informed that Kurukshetra University organizes the Public Speaking Competitions 'ROSTRUM' 2022-23. The competitions will be organized Stage-I at Department level as per following schedule.

Date: 09.02.2023 (Thursday)

Time: 2:00 PM

Venue: Room No. 128, Old Arts Faculty Building, First Floor, KUK

DEAN
Faculty of Arts & Language
K.U. Kurukshetra

DEAN FACULTY OF ARTS & LANGUAGES
KURUKSHETRA UNIVERSITY KURUKSHETRA

(Established by the State Legislature Act XII of 1956)
("A+" Grade, NAAC Accredited)

Dated: 03.02.2023

NOTICE: ROSTRUM: 2022-23 (ANNUAL PUBLIC SPEAKING COMETITIONS)
ROUND-I

All the students of Department of Foreign Languages and Dean Arts & Languages are informed that Kurukshetra University organizes the Public Speaking Competitions 'ROSTRUM' 2022-23. The competitions will be organized Stage-I at Department level as per following schedule.

Date: 09.02.2023 (Thursday)

Time: 2:00 PM

Venue: Room No. 128, Old Arts Faculty Building, First Floor, KUK

DEAN
Faculty of Arts & Languages
KURUKSHETRA UNIVERSITY

ROSTRUM:2022-23
Annual Public Speaking Competition
Results Round-I

Proforma to be completed by all Chairpersons/Directors of Deptt/Institutes/Principal (ITTR & IIHS) and returned to the O/o Dean Students' Welfare by Feb. 11, 2023.

Name of the Deptt./Instt. **DFAL & Foreign Languages** Date of Competition **09-02-2023** Time **2.00 Pm** Venue **Room No 128. Ist Floor.**

Name of the Teacher Coordinator	Mobile No.	Name of the Bank branch (City) with IFSC Code	Account No.
Dr. RASHMI PRADHA	8168264657	SBI. KUK-KR IFSC SBIN0001600	34219025404

Name of the Teacher Judges	Class/Roll No.	Name of the Bank branch (City) with IFSC Code	Account No.
1. Dr. NIDHI MATHUR		SBI. KUK-KR SBI No 001600	20314487691
2. Sumita Devi Verma		SBI Shimla Summer Hill Branch: SBI No 002490	20172503702

Name of the winners with mobile No.	Class/Roll No.	Name of the Bank branch (City) with IFSC Code	Account No.
1 Naveen	04	PNB. sect-3 KURUK. PUR. 10871800 Shetra	8718001500002734
2 Rahul Sharma	40	SBI Mini Secretariat KR	40376967539
3 Anu Rathi	01	SBI 10006615 SBI Haryana Chandra Bank Rewari	7698010102148

Name of Student Comperer	Class/Roll No.	Name of the Bank branch (City) with IFSC Code	Account No.
Bhupinder Singh	02	SBI India, SBI JALLOPUR SBI No 0051227	55155534039

Name of Student Judge	Class/Roll No.	Name of the Bank branch (City) with IFSC Code	Account No.
Nitasha	18	SBI KATHLAL SBI No 003191	38879010789

Total number of Students Speakers 12
 (as per attendance proforma)

Total number of Students who attended the event 54
 Total number of Teachers who attended the event 05

ABR
 Chairperson/Director/Principal
 (Signature with Seal)
 Faculty of Arts & Languages
 K.U. Kurukshetra-136119

ROSTRUM:2022-23
Annual Public Speaking Competition
Round-I
Attendance Proforma of Student Speakers

Attendance Proforma to be sent along with results. Results will not be considered without attendance proforma in any case.

Name of the Deptt./Instt. Dean Faculty of Arts & Languages. E. Foreign Language

Sr. No.	Name of the student	Class	Roll No.	Medium of Speech	Topic of the Student Speaker	Signatures of the Student
1	Atul Tyagi	C-C-UG4	04	Eng.	Topic- 5 R.B.G.C.M.	Atul Tyagi
2	Balkrishan	P.G.DT.	01	Hindi	Topic No - 7	Balkrishan
3	Anu.	C-C-Com-Sk	01	Eng.	Topic - 01	Annu
4	Ritu	"	06	Hindi	Topic - 06	Reety
5	Abimanyu	"	10	Eng.	Topic - 08	Abimanyu
6	Rahul Sharma	C-C-Inher	40	Eng.	Topic - 02	Rahul
7	Naveen	C-C-Geom.	04	Hindi	Topic - 08	Naveen
8	Priya Devi	C-C-in fren.	29	Hindi	Topic - 03	Priya Devi
9	Vanupriya	C-C-In fren.	66	Eng.	Topic - 06	Vanupriya
10	Sonal Nanda	P.G.DT	13	Eng.	Topic - 05	Sonal
11	Karti	C-C-Freng	72	Eng.	Topic - 01	Karti
12	Vinod K. Gupta	Dip'm orde	05	Hindi	Topic - 03	Vinod K. Gupta
13.						

Total number of Student Speakers 12

(as per attendance proforma)

Total number of Students who attended the event 54

Signature of the Teacher Co-ordinator Lash Babhe

Principal Chairperson/Director
 (Signature)
 K.U. Kurukshetra-136119

Rostrum - 2022-23

Stop
Littering
Please



WV P K K O R

23-1-23

ROSTRUM:2022-23

Annual Public Speaking Competition

Results Round-I

Proforma to be completed by all Chairpersons/Directors of Deptt/Institutes/Principal (ITTR & IIIS) and returned to the O/o Dean Students' Welfare by Feb. 11, 2023.

Name of the Deptt./Instt. DFAL Foreign Languages Date of Competition 09-02-2023 Time 2.00 Pm Venue Room No 128 Ist Floor

Name of the Teacher Coordinator	Mobile No.	Name of the Bank branch (City) with IFSC Code	Account No.
<u>Dr. RASHMI PRADHA</u>	<u>8168264657</u>	<u>SBI. KUK KKR</u> <u>IFSC SBIN0001600</u>	<u>34219025404</u>

Name of the Teacher Judges	Class/Roll No.	Name of the Bank branch (City) with IFSC Code	Account No.
<u>1. Dr. NIDHI MATHUR</u>		<u>SBI. KUK KKR</u> <u>SBIN0001600</u>	<u>20314487691</u>
<u>2. Sumita Devi Verma</u>		<u>SBI Shimla, Summer</u> <u>All Branch: SBI No002490</u>	<u>20172503702</u>

Name of the winners with mobile No.	Class/Roll No.	Name of the Bank branch (City) with IFSC Code	Account No.
<u>1. Naveen</u>	<u>04</u>	<u>PNB, Sect-3 KURUKSHETRA</u> <u>PUN 30871800</u>	<u>8718001500002734</u>
<u>2. Rahul Sharma</u>	<u>40</u>	<u>SBI Mini Secretariat KKR</u> <u>SBF 10006615</u>	<u>40376967539</u>
<u>3. Anu Rathi</u>	<u>01</u>	<u>SBI Shimla, Summer</u> <u>PUNB0HG0B001</u>	<u>7698010102148</u>

Name of Student Comperer	Class/Roll No.	Name of the Bank branch (City) with IFSC Code	Account No.
<u>Bhupinder Singh</u>	<u>02</u>	<u>SBI of India, SBI</u> <u>JALLOPUR</u> <u>SBIN0051227</u>	<u>5515534039</u>

Name of Student Judge	Class/Roll No.	Name of the Bank branch (City) with IFSC Code	Account No.
<u>Nitasha</u>	<u>18</u>	<u>SBI KANLUD</u> <u>SBIN0003191</u>	<u>38879010789</u>

Total number of Students Speakers 12
(as per attendance proforma)

Total number of Students who attended the event 54
Total number of Teachers who attended the event 05

 Chairperson/Director/Principal
 (Signature with Seal)
 Faculty of Arts & Languages
 K.U. Kurukshetra-136119

ROSTRUM:2022-23
Annual Public Speaking Competition
Round-I
Attendance Proforma of Student Speakers

Attendance Proforma to be sent along with results. Results will not be considered without attendance proforma in any case.

Name of the Deptt./Instt. Dean Faculty of Arts & Languages. & Foreign Language

Sr. No.	Name of the student	Class	Roll No.	Medium of Speech	Topic of the Student Speaker	Signatures of the Student
1	ATul. Tyagi	C.C. UG4	04	Eng.	Topic - 5 R.P.G.C.M.	Atul Tyagi
2	Bal Krishan	PG.DT.	01	Hindi	Topic No - 7	Bal Krishan
3	Anu.	C.C. Com. SKI	01	Eng.	Topic - 01	Anu
4	Ritu	"	06	Hindi	Topic - 06	Reety
5	Abimanyu	"	10	Eng.	Topic - 08	Abimanyu
6	Rahul Sharma	C.C. in Hindi	40	Eng.	Topic - 02	Rahul
7	Naveen	C.C. in Hindi	04	Hindi	Topic - 08	Naveen
8	Prigya Devi	C.C. in French	29	Hindi	Topic - 03	Prigya Devi
9	Vanupriya	C.C. in French	66	Eng.	Topic - 06	Vanupriya
10	Sonal Nanda	PG.DT	13	Eng.	Topic - 05	Sonal
11	Karti	C.C. Foreign	72	Eng.	Topic - 01	Karti
12	Vinod K. Gupta	Dip. in Hindi	05	Hindi	Topic - 03	Vinod K. Gupta
13.						

Total number of Student Speakers 12
(as per attendance proforma)

Total number of Students who attended the event 54

Signature of the Teacher Co-ordinator Lalita Arora

Principal/Chairperson/Director
(Signature)
Faculty of Arts & Languages
K.U. Kurukshetra-136119

Rostum - 2022 - 23

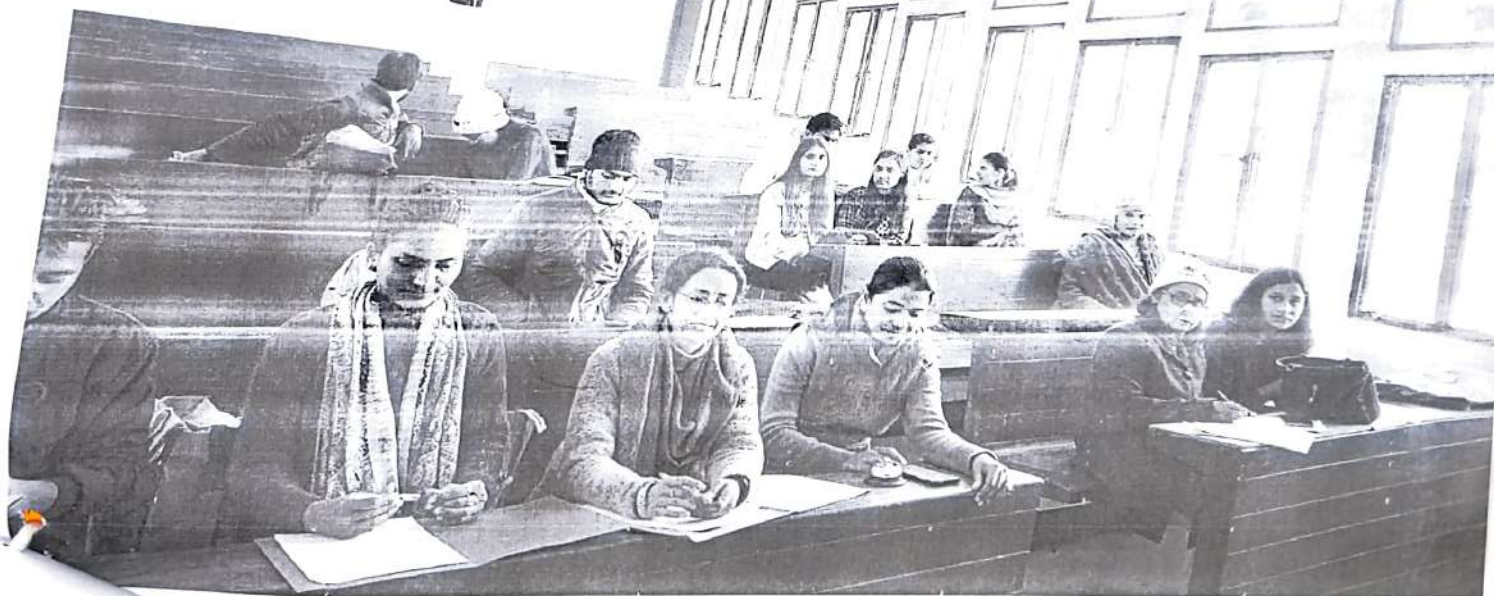

503
533

DEAN FACULTY OF ARTS & LANGUAGES
KURUKSHETRA UNIVERSITY KURUKSHETRA

(Established by the State Legislature Act XII of 1956)
("A+" Grade, NAAC Accredited)

Dated: 03.02.2023

**NOTICE: ROSTRUM: 2022-23 (ANNUAL PUBLIC SPEAKING COMETITIONS)
ROUND-I**

All the students of Department of Foreign Languages and Dean Arts & Languages are informed that Kurukshetra University organizes the Public Speaking Competitions 'ROSTRUM' 2022-23. The competitions will be organized Stage-I at Department level as per following schedule.

Date: 09.02.2023 (Thursday)

Time: 2:00 PM

Venue: Room No. 128, Old Arts Faculty Building, First Floor, KUK

DEAN
Faculty of Arts & Language
K.U. Kurukshetra

विद्यार्थियों के शैक्षणिक विकास के साथ शारीरिक विकास भी जरूरी : डॉ. संजीव शर्मा विद्यार्थियों को लेना चाहिए खेलों में बढ़ चढ़कर भाग : डॉ. तेजेन्द्र शर्मा दीपक ने टाया कहर 29 बॉल में ठोके 85 रन



कुरुक्षेत्र (टी.आर.भटनागर) : कुरुक्षेत्र विश्वविद्यालय के कॉमर्स विभाग की ओर से शनिवार को कुवि के खेल मैदान में एक दिवसीय 3 मैचों की सीरीज का आयोजन किया गया जिसमें कॉमर्स विभाग की दो टीमों सुपर राइजर्स और एलाइट परेडटर्स के बीच यह सीरीज खेली गई। इस अवसर पर कुरुक्षेत्र विश्वविद्यालय के कुलसचिव डॉ. संजीव शर्मा ने भारी मुहूर्तासिद्धि हरी झंडी दिखाकर की इस क्रिकेट प्रतियोगिता का उद्घाटन किया। कुवि कुलसचिव डॉ. संजीव शर्मा ने खिलाड़ियों को प्रोत्साहित करते हुए कहा की विश्वविद्यालय समय-समय पर कैंपस में ऐसे स्पोर्ट्स इवेंट करवाती है जिसमें विद्यार्थियों की प्रतिभा निकल कर आती है और आगे भाषिया में यूनिवर्सिटी का नाम रोशन करते हैं। उन्होंने कहा कि विद्यार्थियों के शैक्षणिक विकास के साथ शारीरिक

विकास भी जरूरी है। डॉ. संजीव शर्मा ने खेलों का महत्व बताते हुए कहा कि खेल के द्वारा व्यक्तियों में गैरतुल्य, अनुशासन एवं आत्मविश्वास जन्मत होता है व व्यक्तियों के व्यक्तित्व में निखार आता है। कॉमर्स विभाग के अध्यक्ष प्रो. तेजेन्द्र शर्मा ने खिलाड़ियों को सम्बोधित करते हुए कहा की विद्यार्थियों को खेलों में बढ़ चढ़कर भाग लेना चाहिए जिससे विद्यार्थियों का शारीरिक एवं मानसिक विकास होता है। उन्होंने इसके दरकें दीर्घा में बड़े विद्यार्थियों कहा की जो विद्यार्थी भाग नहीं ले सके वे भी इस खेल के पैरिफेरिक मूल्या जरूर सीखें इस अवसर पर कुवि कुलसचिव डॉ. संजीव शर्मा व कॉमर्स विभाग की प्रो. नीलम डोंग्रा, डॉ. अजय सुनेजा, डॉ. महापीर, डॉ. सुधा, डॉ. रमि, डॉ. आशीष सांगवान व विभाग के अन्य स्टाफ मेम्बर रहे व मैच का आनंद लिया।

क्रिकेट प्रतियोगिता में सुपर राइजर्स ने मैच जीतकर सीरीज अपने नाम की सुपर राइजर्स की दीपक ने 29 बॉल में ब्रफए 85 रन कॉमर्स विभाग की दो टीमों सुपर राइजर्स एव एलाइट परेडटर्स के बीच आयोजित मैच में सुपर राइजर्स ने पहले दोनों मैच जीतकर सीरीज अपने नाम कर ली। पहले मैच में एलाइट परेडटर्स 88 रनों पर आल आउट हो गई जिसमें सुपर राइजर्स ने आसानी से लक्ष्य को हासिल कर लिया। इस मैच में विजय ने लगातार 4 विकेट लेकर बेहतरीन गेंदबाजी का प्रदर्शन करते हुए दूसरी टीम की कमर तोड़ दी। यही दूसरे मैच में सुपर राइजर्स ने 90 ओवर में एलाइट परेडटर्स के सामने 126 रनों का विशाल लक्ष्य रखा जिसमें सुपर राइजर्स की ओर से दीपक ने 29 बॉल में 85 रन ठोके। यही काबू में एलाइट परेडटर्स 100 रन ही बना सकी।

खेल प्रतियोगिताओं से निखरती है विद्यार्थियों की प्रतिभा : डा. संजीव

जगरण संवाददाता, कुरुक्षेत्र : कुरुक्षेत्र विश्वविद्यालय के खेल मैदान में शनिवार को वाणिज्य विभाग की ओर से एक दिवसीय तीन मैचों की सीरिज आयोजित की गई।

विभाग की सुपर राइजर्स और एलाइट परेडटर्स के बीच खेली गई सीरीज में सुपर राइजर्स टीम विजेता रही। सुपर राइजर्स के दीपक ने मैच में 29 बाल में 85 रन बनाकर सीरीज अपनी टीम के खाते में डाली। सुपर राइजर्स की टीम ने पहले दोनों मैच जीतकर अपनी प्रतिभा का लोहा मनवाया। पहले मैच में एलाइट परेडटर्स की टीम 48



कुवि खेल मैदान में आयोजित प्रतियोगिता का शुभारंभ करते कुलसचिव डा. संजीव शर्मा।

रनों पर आल आउट हो गई। इस मैच में सुपर राइजर्स ने आसानी से लक्ष्य को हासिल कर लिया। इस मैच में विजय ने लगातार चार विकेट

लेकर बेहतरीन गेंदबाजी का प्रदर्शन करते हुए दूसरी टीम की कमर तोड़ने का काम किया। वहीं दूसरे मैच में सुपर राइजर्स ने 10 ओवर में

एलाइट परेडटर्स के सामने 126 रनों का विशाल लक्ष्य रखा। इसमें सुपर राइजर्स की ओर से दीपक ने 29 बाल में 85 रन ठोके। इसके जवाब में एलाइट परेडटर्स की टीम 100 रन ही बना सकी और आलआउट हो गई।

क्रिकेट मैच का शुभारंभ करते हुए कुलसचिव डा. संजीव शर्मा ने कहा कि विवि समय-समय पर परिसर में ऐसे स्पोर्ट्स इवेंट करवाती है, जिसमें विद्यार्थियों की प्रतिभा निखरती है। उन्होंने कहा कि विद्यार्थियों के शैक्षणिक विकास के साथ शारीरिक विकास भी जरूरी है।

राइजर्स ने परेडटर्स को हराकर सीरीज जीती

संवाद न्यूज एजेंसी

कुरुक्षेत्र। कुरुक्षेत्र विश्वविद्यालय (केयू) के कॉमर्स विभाग की ओर से शनिवार को केयू के खेल मैदान में एक दिवसीय तीन मैचों की सीरीज का आयोजन किया गया। विभाग की दो टीमों सुपर राइजर्स और एलाइट परेडटर्स के बीच यह सीरीज खेली गई। मैच में सुपर राइजर्स ने अपने पहले दोनों मैच जीतकर सीरीज अपने नाम कर ली।
मुख्यातिथि केयू कुलसचिव डॉ. संजीव शर्मा ने प्रतियोगिता का आरंभ किया।

पहले मैच में एलाइट परेडटर्स 48 रनों पर ऑल आउट हो गईं। सुपर राइजर्स ने आसानी से लक्ष्य को हासिल कर लिया। इस मैच में विजय ने लगातार चार विकेट लेकर बेहतरीन गेंदबाजी का प्रदर्शन किया। दूसरे मैच में सुपर राइजर्स में 10 ओवर में एलाइट परेडटर्स के सामने 126 रनों का विशाल लक्ष्य रखा, जिसमें सुपर राइजर्स की ओर से दीपक ने 29 बॉल में 85 रन ठोके। वहीं जवाब में एलाइट परेडटर्स 100 रन ही बना सकी। कुलसचिव डॉ. संजीव शर्मा ने कहा कि विद्यार्थियों के शैक्षणिक विकास के साथ शारीरिक विकास भी



प्रतियोगिता की शुरुआत करते डॉ. संजीव शर्मा।

जरूरी है। खेल से व्यक्ति में नेतृत्व, अनुशासन एवं आत्मविश्वास जागृत होता है और व्यक्तित्व में भी निखार आता है। कॉमर्स विभाग के अध्यक्ष प्रो. तेजेंद्र शर्मा ने विद्यार्थियों को खेलों में बढ़ चढ़कर भाग लेने के लिए प्रेरित किया।

कहा कि खेल से शारीरिक व मानसिक विकास होता है। उन्होंने दर्शक दीर्घा में बैठे विद्यार्थियों को खेल के नैतिक मूल्य सीखने के लिए प्रेरित किया। इस मौके पर प्रो. नीलम ढांडा, डॉ. अजय सुनेजा, डॉ. महावीर, डॉ. सुभाष, डॉ. रश्मी, डॉ. आशीष सांगवान आदि मौजूद रहे।

विद्यार्थियों के शैक्षणिक विकास के साथ शारीरिक विकास भी जरूरी: डॉ. संजीव

कुरुक्षेत्र। कुरुक्षेत्र विश्वविद्यालय के कॉमर्स विभाग की ओर से शनिवार को कुवि के खेल मैदान में एक दिवसीय 3 मैचों की सीरीज का आयोजन किया गया जिसमें कॉमर्स विभाग की दो टीमों सुपर राइजर्स और एलाइट परेडटर्स के बीच यह सीरीज खेली गई। इस अवसर पर कुरुक्षेत्र विश्वविद्यालय के कुलसचिव डॉ. संजीव शर्मा ने बतौर मुख्यातिथि हरी झंडी दिखाकर की इस क्रिकेट प्रतियोगिता का आरम्भ किया। कुवि कुलसचिव डॉ. संजीव शर्मा ने खिलाड़ियों को प्रोत्साहित करते हुए कहा की विश्वविद्यालय समय-समय पर कैंपस में ऐसे स्पोर्ट्स इवेंट करवाती है जिसमें विद्यार्थियों की प्रतिभा निकल कर आती है और आगे भविष्य में यूनिवर्सिटी का नाम रोशन करते है। उन्होंने कहा कि विद्यार्थियों के शैक्षणिक विकास के साथ शारीरिक विकास भी जरूरी है। डॉ. संजीव शर्मा ने खेलों का महत्व बताते हुए कहा कि खेल के द्वारा व्यक्ति में नेतृत्व, अनुशासन एवं आत्मविश्वास जागृत होता है व व्यक्ति के व्यक्तित्व में निखार आता है। इस अवसर पर कुवि कुलसचिव डॉ. संजीव शर्मा व कॉमर्स विभाग की प्रो. नीलम ढांडा, डॉ. अजय सुनेजा, डॉ. महावीर, डॉ. सुभाष, डॉ. रश्मि, डॉ. आशीष सांगवान व विभाग के अन्य स्टाफ मौजूद रहे व मैच का आनंद लिया।

Event Report

Unnayan – 2022

October 6th, 2022

The annual Induction programme 'Unnayan – 2022' was organised by the Institute of Management Studies. The venue for the event was Senate Hall of Kurukshetra University, Kurukshetra. The event was organised for the orientation of newly admitted students of MBA 5 year and BBA (Hons.). During the induction programme approximately 150 students and more than 30 faculty members & research scholars were present. Prof. Anil Vashisth was the Chief Guest of the event and the Keynote Speaker for the session was Mr. Anuraag Rishi. The event also hosted three Guest of Honor, Dr. D. D. Arora, Dr. B. S. Bodla and Dr. Sunita Dalal. Prof. Anil Mittal, Director, Institute of Management Studies also joined the dignitaries.

The Chief guest inaugurated the event with Deep Prajawalan and Sarswati Vandana was performed by the students of the institute. Dr. J. K. Chandel welcomed all the guest on behalf of the institute and thanked them for joining us for this special event of our institute. The Vice-chancellor, Prof. Somnath Sachdeva and Registrar, Dr. Sanjeev Sharma addressed the students through video byte mode and congratulated the newly admitted pupils. Afterwards, our chief guest of the day, Prof. Anil Vashisth addressed the audience and motivated them to contribute to build a better society. He also, added that all the facilities related to academics, research, cultural, sports and health are available to all the students and each student should make best use of all theses facilities to build a strong character and excel in their academic career. The former Directors of the institute Prof. D. D. Arora and Prof. B. S. Bodla blessed the students and shared their experiences with them. They also motivated the newly inducted students to work hard to achieve their goals. Dr. Sunita Dalal, Warden Girls' Hostel no. I, narrated about all the hostel facilities provided by the

University especially for the girl students. The Director, Prof. Anil Mittal assured all the students and their parents that their future is in safe hands. He also insisted the students to take up all the opportunities made available to them by the institute & University. In addition to that, Dr. Anil Kumar, Assistant Professor, elaborated all the courses and facilities of the institute. Dr. Anil Kumar also took a session about the "Code of Conduct" to make the students familiar with it.

The Keynote Speaker of the day, Mr. Anuraag Rishi encouraged the students with real life events to excel in their life and smartly overcoming all the obstacles in their way. He also propagated to have a clear vision and commitment to their goals. The programme was concluded with delivery of Vote of Thanks by the Deputy Director, Dr. Rajan Sharma to Prof Somnath Sachdeva, Dr. Sanjeev Kumar, Prof. Anil Vashisth, Dr. D. D. Arora, Dr. B. S. Bodla, Dr. Sunita Dalal, Mr. Anuraag Rishi, Prof. Anil Mittal, Dr. Anil Kumar, Dr. J. K. Chandel, Dr. Mamta Bhardwaj, Dr. Meenakshi Godara, Dr. Palak Bajaj, Ms. Disha Kakkar, Ms. Sangeeta Dhir and research scholars Mr. Jayant Dalal, Mr. Vikram and Ms. Latika. He emphasized that students should actively pursue their goals in order to succeed and prosper in their life.

The feedback of the event from the students and Faculty members was very positive and students enjoyed all the activities.

Deputy Director
Institute of Management Studies
Konveer University, Kurukshetra

06-10-2022

Unnayan – 2022 (Induction Programme)

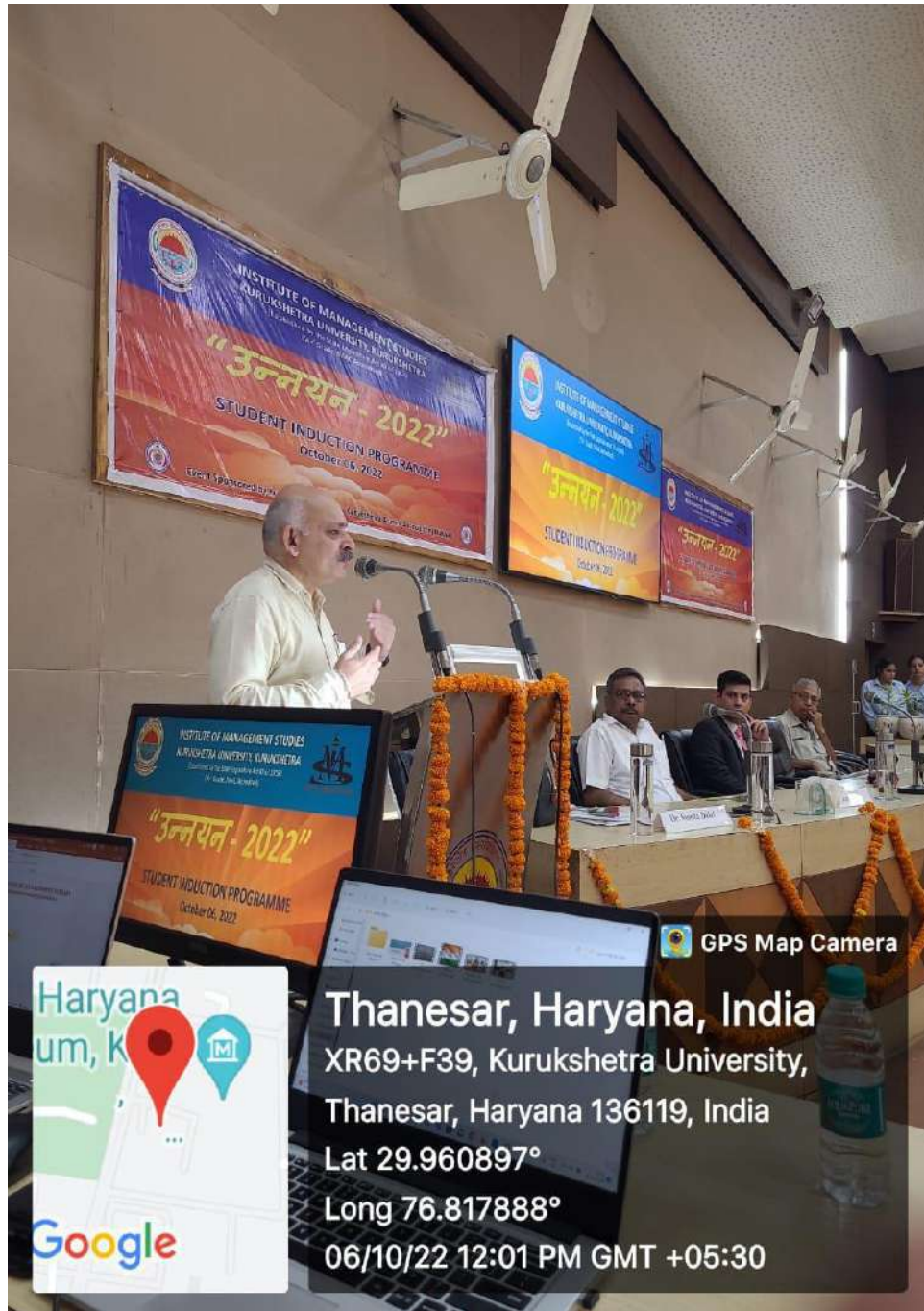

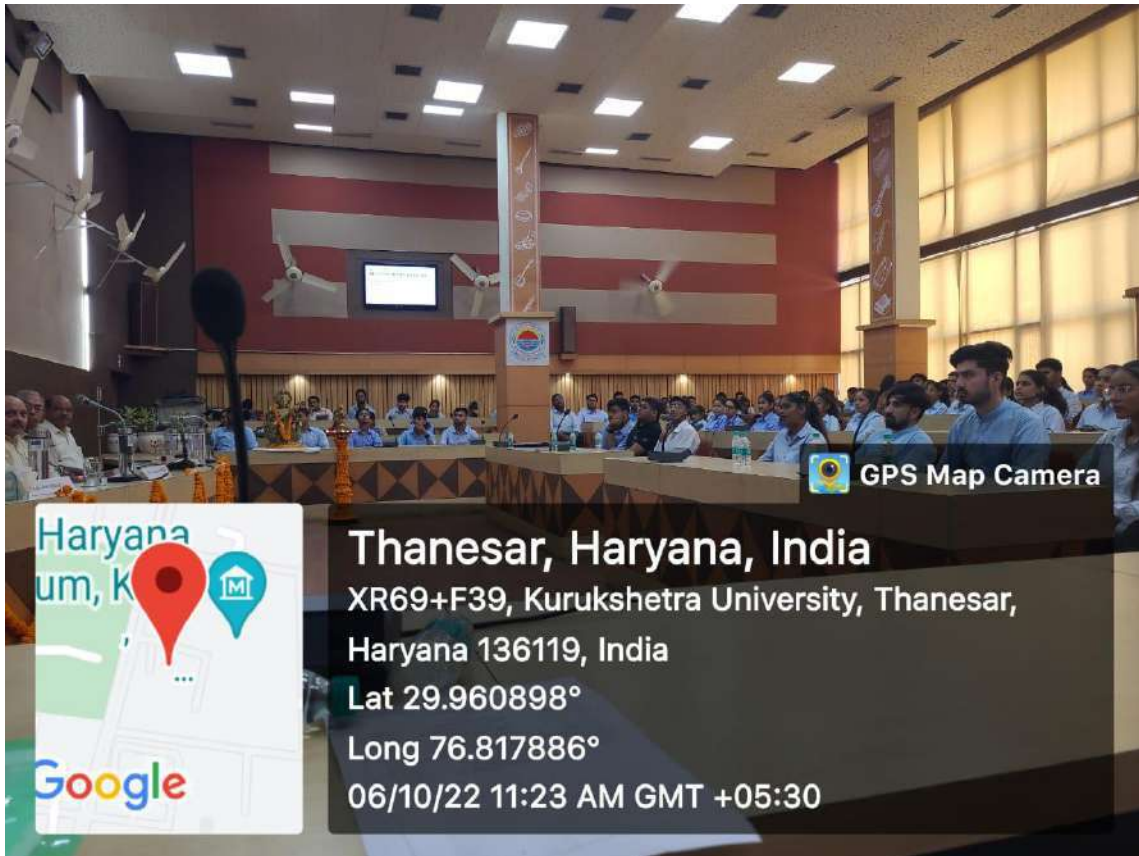

November 23, 2022

Report on Educational tour to India International Trade fair (IIFT)

A tour to **India International Trade fair** was organized for students of Institute of Management Studies on 23.11.2022. The tour was accompanied by the staff members Dr. Anil Kumar, Dr. Meenakshi Godara, and Ms. Leeza Chauhan.

About IITF

The **India International Trade Fair**, ever since its inception in 1980, has evolved as a major event for the business community. It is a premier event organized by the India Trade Promotion Organization, the nodal trade promotion agency of the Govt of India. The event is held between 14th and 27th November every year at Pragati Maidan, New Delhi, India.

Purpose of Trip

1. IITF is a major tourist attraction. The annual event provides a common platform for the manufacturers, traders, exporters and learners to engage in one-on-one activities and learn through them.
2. The fair displays comprise a wide range of products and services including automobiles, coir products, jute, textiles, garments, household appliances, kitchen appliances, processed food, beverages, confectionery, pharmaceuticals, chemicals, cosmetics, body care & health care products, telecommunication, power sector, electronic sector, furniture, home furnishings, sporting goods, toys, and engineering goods. Which aims at increasing the knowledge of students
3. All business avenues were encouraged to participate, to represent India in its totality and open fresh avenues for major business expansion.

University Tour by Institute of Management Studies

6:00 AM - Departure from Institute's Parking (Institute of Management Studies)

9:00 AM – Breakfast break at 70 Milestone Dhaba near Panipat.

11.15 AM – Arrival at IIFT, Pragati Maidan (New Delhi)

11.30 AM – Entry inside International trade fair in Pragati maidan (New Delhi).

Trade Fair – The ground level trade fair consists of various mixed stalls which includes food items from various states of India and neighbouring countries such as Afghanistan, Nepal, Srilanka.

Delhi Pavilion – The Pavilion of the Delhi Government at the 41st International Trade Fair being held at Pragati Maidan in Delhi this year will showcase Delhi as ‘**the city that cares**’. Those coming to the Delhi Pavilion will see a glimpse of education, health, infrastructure, electricity, water, transport, tourism, and policies to reduce inflation.

Gujarat pavilion – Gujarat Pavilion has successfully depicted the implementation of e-governance projects which include State Wide Area Network, State Data Centre, eGRAM, Common Service Centres (CSCs) etc.

Uttar Pradesh Pavilion – Various sectoral policies to promote industrial development like the recently launched MSME policy, all of which were being reviewed and revised by the government to suit the current environment.

Thailand Pavilion – One can explore traditional Thailand dresses being sold at an affordable budget of Rs 1000. One can buy an unlimited variety of accessories at these stalls from claw clips to scrunchies. There is another stall ahead waiting for you, they are selling stunning artificial jewellery sets and an affordable price.

Turkey pavilion – The turkey stall is the highlight of every year IITF. The lamps and the colourful crockery transport you to Istanbul. The stunning-looking lamps with defined work can be found here. Besides the crystal cut lamps, they also have distinguished culinary.

7:00 PM – Departed from Pragati Maidan for Kurukshetra University.

9:00 PM – Took dinner break at Shiva Dhaba.

12:00 PM – Reached Kurukshetra University back from IITF.

Report prepared by
Anmol Bhardwaj
Roll No. 49, MBA 5-Rear, 10th Semester

December 9th, 2022

EVENT REPORT- INNOCREATE 2022

Institute of Management studies organized the grand cultural event of Institute ‘‘ Innocreate 2022’’ in RK Sadan of Kurukshetra University on 9th December 2022. This was also preceded by number of competitions like Best out of Waste, Cooking without Fire and Photography held in the premises of Institute and Department of Hotel Management on 8th December 2022. The program began with the pious Saraswati Vandana and Lamp Lightening by all the dignitaries. The Chief Guest Dr. Nirmala Chaudhary, Chairperson (USM) graced the occasion by her presence and congratulated the Department for this initiative. She also gave her blessings to the students and inspired them with her words of wisdom. Most students of IMS along with students from University School of Management, Department of Fine Arts, Department Of Hotel and Tourism Management participated actively in this event and showcased their talent in numerous cultural activities. Three winners were selected for each cultural activity. The Department provided the certificates and mementoes to all the winners. Some students like Tirthankar, Palak, Jabir, Ankit, Yashank, Anmol etc. played an active role in organizing the event successfully under the guidance of Dr. Rajan Sharma, Deputy Director of IMS. Prof. Anil Mittal, Director, IMS applauded the efforts of students and faculty for successful organization of the event. Faculty of IMS, Dr. Anil Kumar, Dr. JK Chandel, Dr. Rajan Sharma, Dr. Mamta Bhardwaj, Dr. Meenakshi Godara, Dr. Disha Kakkar, Dr. Palak Bajaj and Ms. Sangeeta worked collectively to make this event a grand success.



Deputy Director

Deputy Director
Institute of Management Studies
Kurukshetra University, Kurukshetra

December 10th, 2022

EVENT REPORT- ALUMNI MEET

Institute of Management Studies organized "ALUMNI MEET" on 10/12/22. The program started with the lamp lighting and paying obeisance to the Goddess Sarasvati by all the dignitaries. This was followed by Ganesh Vandana and a welcome address by worthy Director of IMS Prof Anil Mittal. In his address, he thanked the Vice Chancellor for gracing the Event and also shared some valuable information about **KUKAA (Kurukshetra University Kurukshetra Alumni Association)** and about a variety of financial aids and scholarships provided by the Association to the needful students. He congratulated the students who were winners in the cultural activities of Innocreate 2022. He also motivated the students by presenting them with the mementoes and certificates. Prof. Somnath Sachdeva, honorable Vice Chancellor graced the program as the Chief Guest. He delivered a remarkable speech highlighting the importance of bond between the various Institutes and their respective Alumni. He congratulated the Institute for organizing the event successfully and blessed the students with his remarkable words. 60 Alumni of various batches were present in the Event. Vice Chancellor in his address advised the Alumni to support and guide the current students of their Alma mater whole heartedly for their training and placements. This was followed by a string of spectacular cultural events like Nukkad Nataks, Solo and Group Dances and Ramp Walk. The alumni were called on the stage to share their memories of their college life and give blessings and direction to the current students. The event beautifully showcased the memories of the Alumni. All the teachers and students put in their efforts collectively to make this event a grand success. The faculty of Institute of Management Studies Dr. Rajan Sharma, Dr. JK Chandel, Dr. Anil Kumar, Dr. Mamta Bhardwaj, Dr. Meenakshi Godara, Dr. Palak Bajaj, Ms. Disha Kakkar and Ms. Sangeeta also attended the event and encouraged the students for their participation.

Deputy Director
Deputy Director
Institute of Management Studies
Kurukshetra University, Kurukshetra

09/10 December 2022 Innocreate – 2022 (Cultural Event)



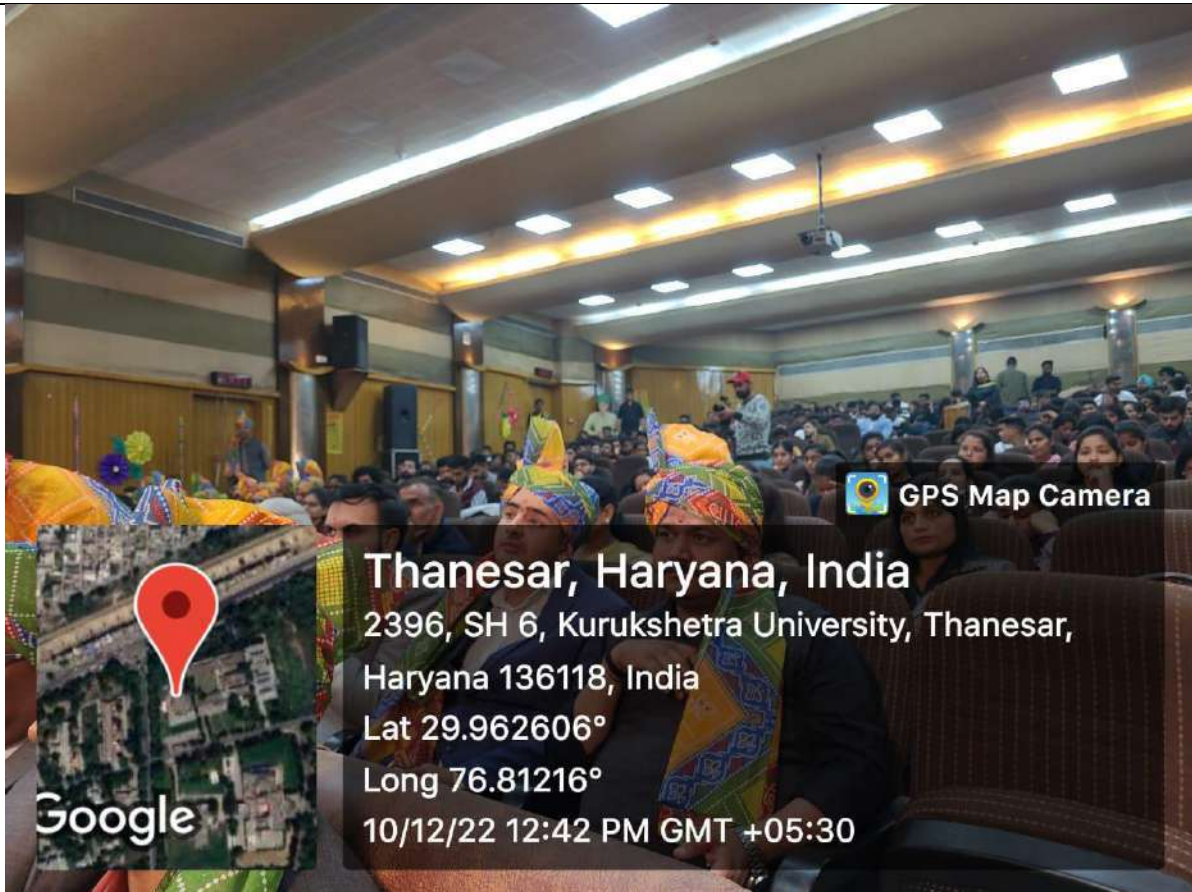

Industrial Visit at T.C. SPINNERS PVT. LTD, Lalru, Punjab

An Industrial visit was held for 42 students of Institute of Management Studies at T.C. SPINNERS PVT. LTD. accompanied by the staff members Dr. Anil Kumar, Dr. Meenakshi Godara, and Ms. Leeza Chauhan. The students arrived at T.C. SPINNERS PVT. LTD., where Mr. Vijay Girdhar, the organization's head of human resources, greeted and gave a brief overview of the organization. The students split up into three smaller groups for each student to comprehend how the business operates. One senior officer served as the leader of each group. The following describes the route to the industry:

- ✓ Two processes—the "spinning process," in which raw cotton is transformed into thread, and the "weaving process," in which the thread is woven into fabric—are utilized to create the fabric that is typically used for our clothing. Using a mixing and blowing equipment, the compacted staple fiber brought to the spinning facility is unraveled to start the spinning process. Next it is cleaned by getting rid of anything stuck to it, including sand, seeds, or fallen leaves. The staple fiber is then transformed into "lap" in the form of sheets.
- ✓ The cotton is next altered into lap sheets in the second stage. The microscopic dust particles are eliminated at a temperature of 32 to 33 degrees, and the cotton is subsequently turned into rope-like thread. The carding machine is used to separate the fibers and remove short fibers and fine dust from the sheet-shaped lap that was produced during the mixing and blowing process. The remaining long fibers are gathered and approximately parallel-aligned before being processed into "carded sliver," which resembles a string. Twenty people are currently employed there, but the staff estimates that eventually all work in that area will be performed by robots. 18 to 24 carded slivers are fed side by side in a single feeding. They are drafted and a loose form of web is created. The web is rolled up to a lap. This is called "sliver lap." The carded sliver is further combed to remove short fibers and dust that could not be removed in the carding process. Fibers are then arranged parallel to obtain uniform combed sliver. This process is essential to manufacture uniform, high-quality yarn. Six to eight slivers after the carding or combing process are gathered and elongated to six to eight times their original length using a drawing machine to straighten and remove uneven thickness from the fibers. This process transforms fibers into string-like "drawn sliver." Since the drawn sliver is too thick to produce yarns directly, it is further

elongated using a roving machine. Twisting is first applied to fibers in this process to obtain the green yarn, which is wound onto a bobbin.

- ✓ The temperature of the area grows together with the size of the stage. Due to the needs of the machinery, the temperature is kept around 42 to 44 degrees in the third step. The saliver is converted into cotton threads at this stage, and after passing through numerous machineries, the thread gains strength and sharpness. The green yarn produced by the roving process is further stretched to the necessary thickness and then twisted in the fine spinning process, the final of the primary spinning processes. The finished item, or yarn, is wound onto a bobbin. Rewinding the finished yarn onto bobbins and placing it into a cheese or cone, depending on its use, is the winding process.
- ✓ The cotton loses moisture throughout the process. The final inspection of the thread is then performed twice in order to assess its quality and restore the moisture, and then it is wrapped in plastic bags for delivery. The owners invested approximately 75 crores throughout the entire procedure. The organization primarily works in the overseas supply of cotton threads from India and focuses on the quality of the cotton threads. As machines become more sophisticated and full robotic machine operation is anticipated in the future, the number of employees is steadily declining.

After that, we were taken to a meeting room where Mr. Kamalnath, the head of the technical department, Mr. Pardeep Singh, the head of the IT cell, and Mr. Vijay Girdhar answered all the queries of the students and clarified their doubts while educating them on the organization's administration. They finished the meeting by sharing a small treat. After giving letter of appreciation from the Institute, the faculty members concluded their visit.

--sd--

Director
Institute of Management Studies
Kurukshetra University Kurukshetra

REPORT ON CULTURAL TOUR (19-03-2023 TO 22-03-2023)

An Educational-cum-Entertainment Tour to Manali and Kasol was organized for 42 students of Institute of Management Studies. The tour was accompanied by the staff members, namely Dr. Anil Kumar, Dr. Meenakshi Godara, and Ms. Leeza Chauhan.

Day 1:

The students reached Manali, Himachal Pradesh at 7:45 AM and check-in into the hotel at 8:30 AM. After breakfast, all left for **Sissu Valley** and took cabs, and rented warm clothes and snow boots suitable for the weather at the valley. On the way to Sissu Valley, all enjoyed beauty of Solang Valley and Atal Tunnel which is of 8.5 KM long.

At Sissu Valley, everyone enjoyed various activities like – Zipline, playing in snow, enjoyed snowfall, eating “pahadon ki maggi and momos” and their famous local dish called Siddu. Everyone came back to the hotel by 6:30 PM and had dinner at 9:00 PM.

Day 2

Everyone woke up, got ready, had breakfast, checked-out from hotel at 11:00 AM to visit Mall Road & Hadimba Temple in Manali. At 4:00 PM, all left for Kasol. Students reached Kasol Riverside Campsite (KASOL ADVENTURE CAMP) at 7:00 PM and got settled in camps. Everyone enjoyed the beauty of riverside campsite and had dinner at 9:00 PM and enjoyed the DJ night and Bonfire till 10:30 PM.

Day 3

Everyone woke up, got ready, had breakfast and checked-out from the camps at 12:00 PM and went to Gurudwara Manikaran Sahib by local buses. Everyone enjoyed langar at Gurudawara and then went back to the local market of Kasol at 3:00 PM. At 8:00 PM, the tour departed from Kasol and reached Kurukshetra University by next morning at 6:45 AM (22.03.2023).

It was a cultural tour that all enjoyed and cherished.

--sd--

Director
Institute of Management Studies
Kurukshetra University Kurukshetra

May 8th, 2023

Tree Plantation drive in Institute of Management Studies, KUK

Institute of Management Studies with the collaboration of National Social Organisation organized a tree plantation on May 8th, 2023 at the institute. On this occasion, Deputy Director of the institute Dr. Rajan Sharma motivated the students and gave message to protect and conserve the environment. While addressing the students Dr. Sharma thanked the National Social Organisation team and appreciated their efforts to preserve the environment. He also encouraged the students of BBA and MBA to keep their premises clean and green. Along with Dr. Rajan Sharma other faculty members Dr. Anil Kumar, Dr. Mamta Bhardwaj, Dr. Meenakshi Godara, Dr. Palak Bajaj, Ms. Leeza Chauhan, Dr. Rajni, Ms. Shweta Vashisth, Mr. Jayant Dalal and Ms. Sarita Pathania were present with the students of the institute and team of NSO.



Deputy Director

Deputy Director
Institute of Management Studies
Kurukshetra University, Kurukshetra

04-05-2023 Tree Plantation



04-05-2023 Tree Plantation



08-05-2023 Industrial Visit at Blue Star, Ogli (Himachal Pradesh)





KURUKSHETRA UNIVERSITY KURUKSHETRA

(Established by the State Legislature Act XII of 1956)

(*A+* Grade, NAAC Accredited)



Dr. Rajesh Sobti
Director Phy. Edu. & Sports
& Secretary, K.U. Sports Council

Phones: Office. 01744-238074

Mob. No. 9467054670

Email: kuksports@gmail.com

No. Sports/23/ 373-78
Dated 14.2.2023

To

The Registrar/DirectorSports/SportsOfficer/Secretary Sports Committee/
Council of the Member Universities.

Subject: **North Zone Inter University Cricket (Men) Championship 2022-23**

Sir/Madam,

On behalf of the Hon'ble Vice-Chancellor, Sports Council, Staff Members, the Management Committee and the students of Kurukshetra University, it gives me immense pleasure in welcoming you to the North Zone Inter University Cricket (Men) Championship 2022-23 to be organized at Kurukshetra University. The schedule of the Championship is as under:-

Sr.	Tournament	Dates of Tournament
1.	North Zone Inter University Cricket (Men) Champ. 2022-23	23 rd February to 04 th March, 2023

On behalf of Kurukshetra University, I extend a very cordial welcome to your team to participate in this Championship at the Holy City.

Encl:

- i. Fixtures
- ii. Information Brochure
- iii. Manual for AIU Registration Fee

Organizing Secretary
NZ & AIU Championship 2022-23.
14/02/2023

C.C:

1. Dr. Baljit Singh Sekhon, Joint Secretary Sports, AIU, New Delhi for kind information.
2. President & Vice-President, K.U. Sports Council for kind information.
3. O.S.D. to Vice-Chancellor for kind information.
4. P.S. to Vice-Chancellor/Registrar (for kind information of the Vice Chancellor/ Registrar)
5. Director, Public Relations, KUK for kind information and necessary action.



KURUKSHETRA UNIVERSITY KURUKSHETRA

(Established by the State Legislature Act XII of 1956)

('A+' Grade, NAAC Accredited)

Directorate of Sports

Fixtures for North Zone Inter University Cricket (Men) Championship, 2022-23

(From 23rd February to 04th March, 2023)

POOL-A

CSJM Uni, Kanpur (LYRU)

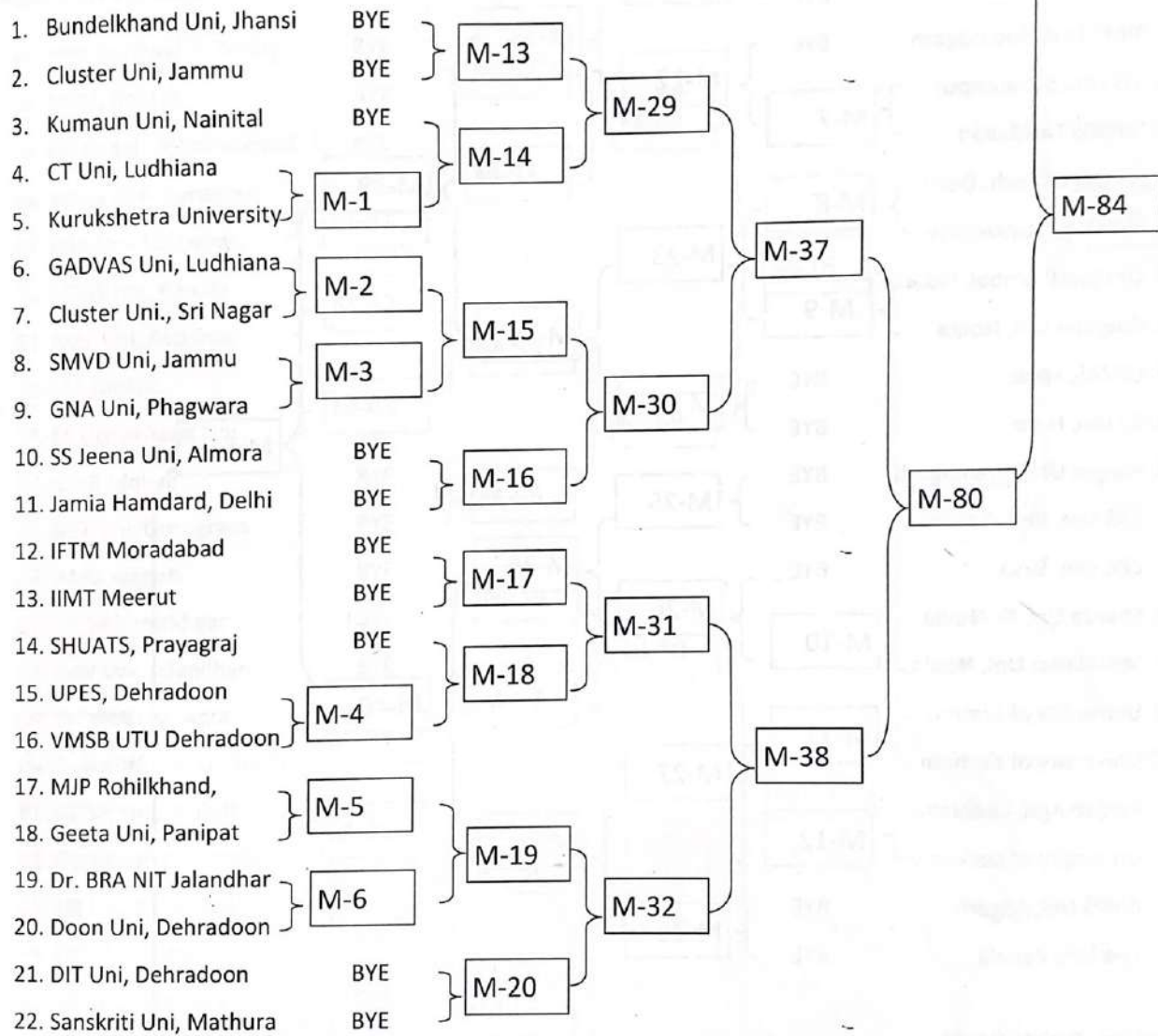



KURUKSHETRA UNIVERSITY KURUKSHETRA

(Established by the State Legislature Act XII of 1956)

('A+' Grade, NAAC Accredited)

Directorate of Sports

Fixtures for North Zone Inter University Cricket (Men) Championship, 2022-23

(From 23rd February to 04th March, 2023)

POOL-B

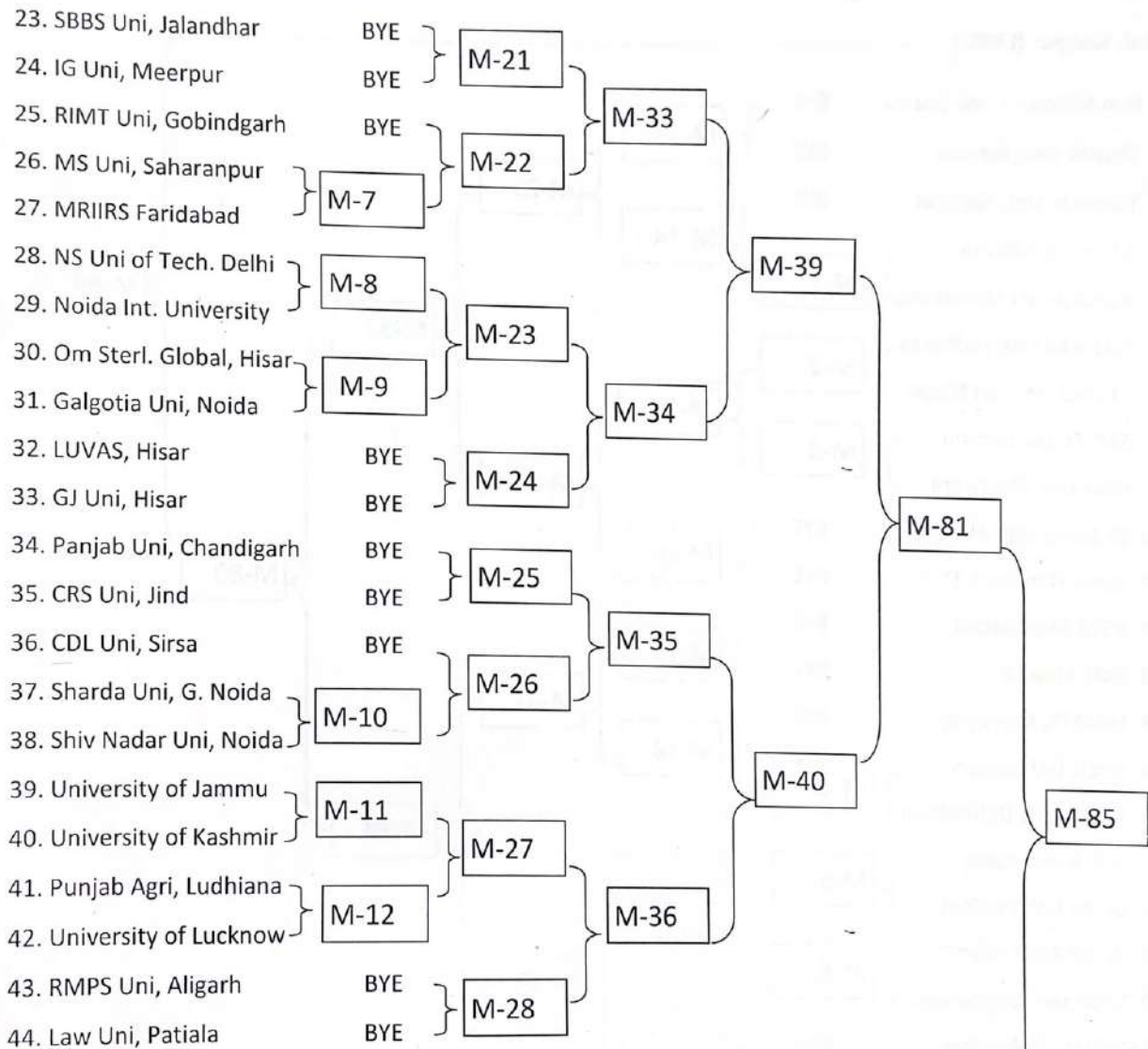

Punjabi Uni, Patiala (LYSF)



KURUKSHETRA UNIVERSITY KURUKSHETRA

(Established by the State Legislature Act XII of 1956)

('A+' Grade, NAAC Accredited)

Directorate of Sports

Fixtures for North Zone Inter University Cricket (Men) Championship, 2022-23

(From 23rd February to 04th March, 2023)

POOL-C

Al-Falah Uni Faridabad (LYSF)

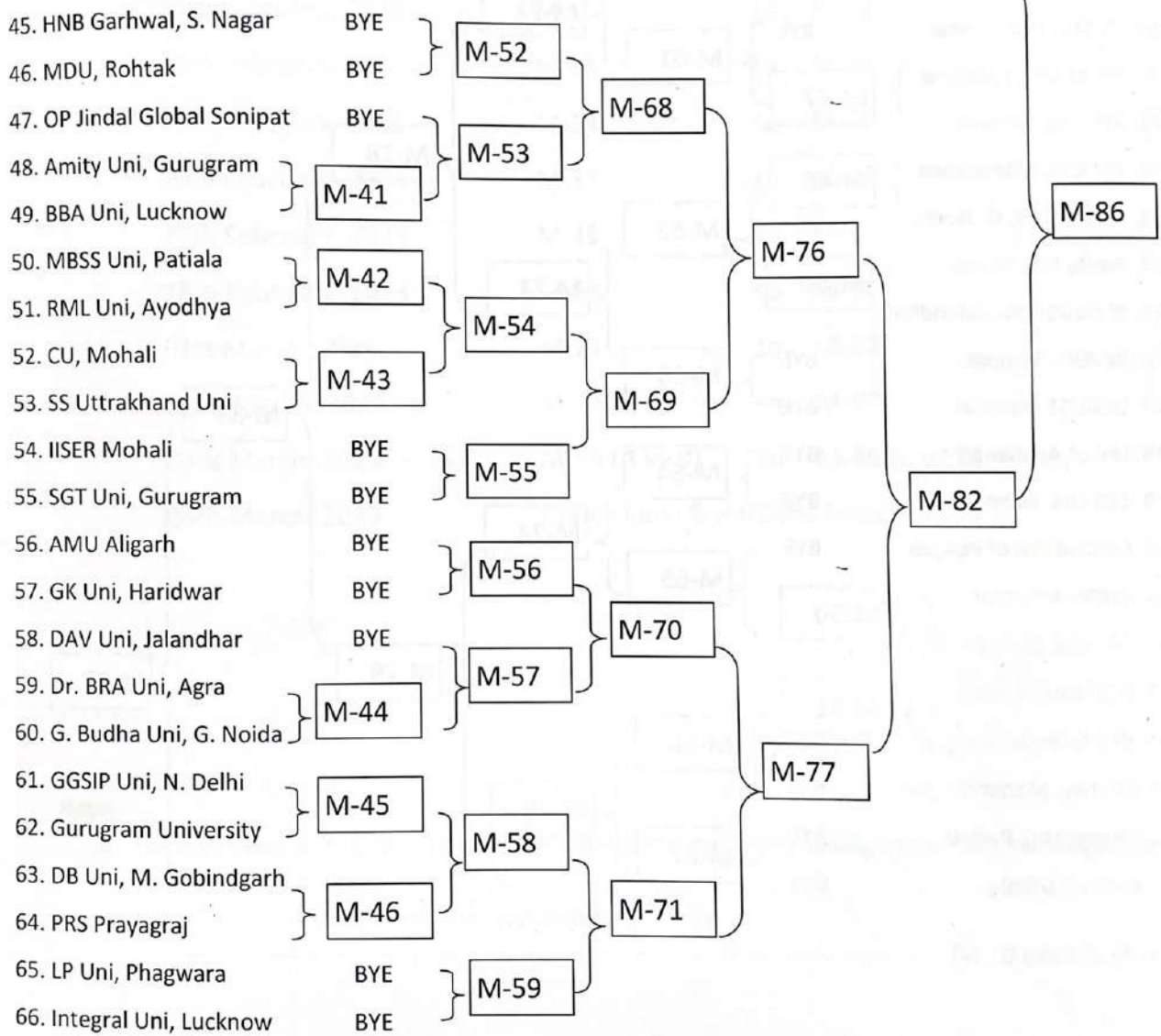



KURUKSHETRA UNIVERSITY KURUKSHETRA

(Established by the State Legislature Act XII of 1956)

('A+' Grade, NAAC Accredited)

Directorate of Sports

Fixtures for North Zone Inter University Cricket (Men) Championship, 2022-23

(From 23rd February to 04th March, 2023)

POOL-D

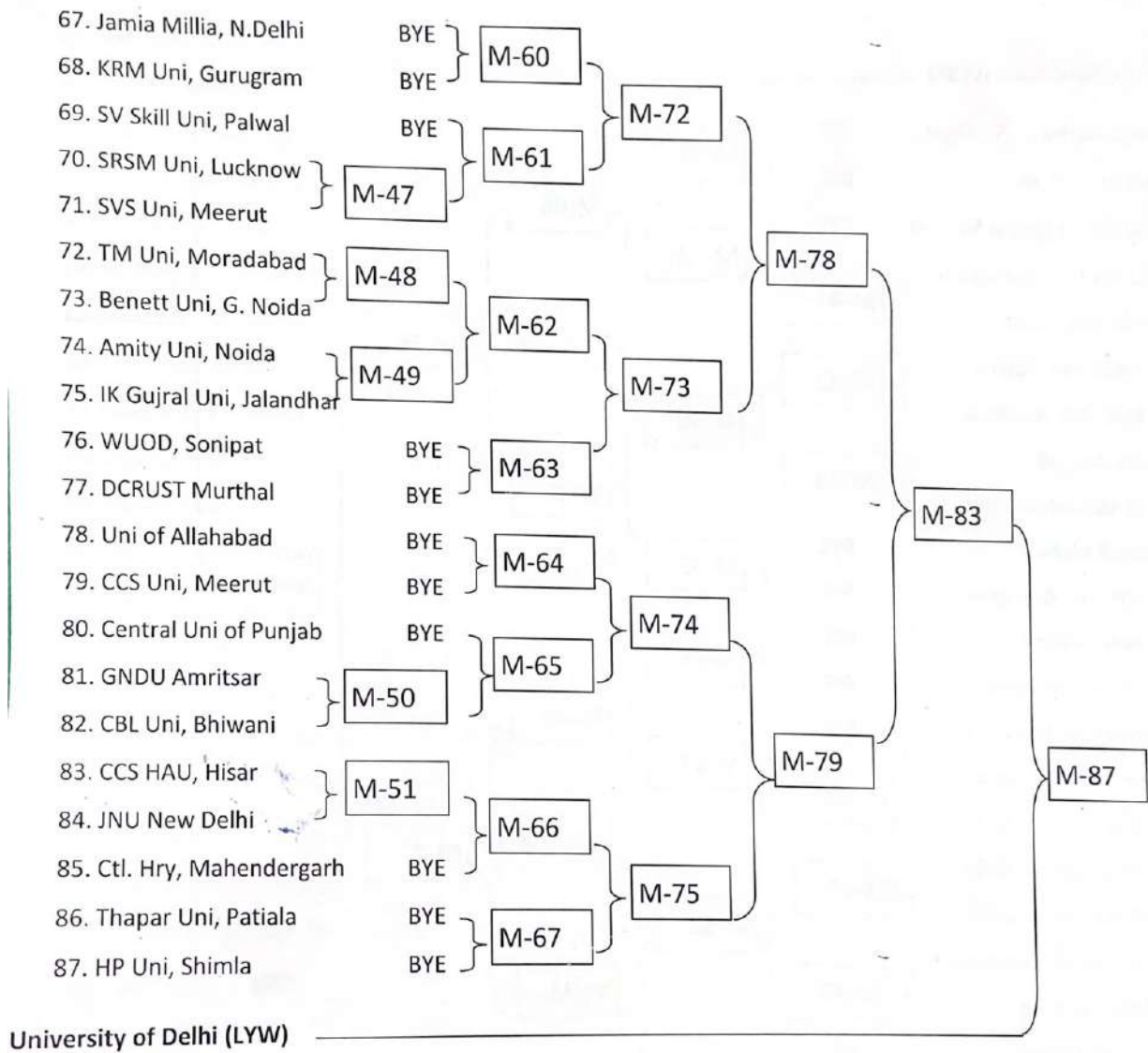



KURUKSHETRA UNIVERSITY KURUKSHETRA

(Established by the State Legislature Act XII of 1956)

('A+' Grade, NAAC Accredited)

Directorate of Sports

Fixtures for North Zone Inter University Cricket (Men) Championship, 2022-23

(From 23rd February to 04th March, 2023)

The schedule of the matches is as under:

23rd February, 2023	M-1	to	M-12
24th February, 2023	M-13	to	M-24
25th February, 2023	M-24	to	M-36
26th February, 2023	M-37	to	M-48
27th February, 2023	M-49	to	M-60
28th February, 2023	M-61	to	M-72
01st March, 2023	M-73	to	M-83
02nd March, 2023	M-84	to	M-87
03rd March, 2023 - S.F.	M-88 (A vs B)	to	M-89 (C vs D)
04th March, 2023	Match Final & Hardline Match		

Organizing Secretary

Note:

1. The organizing secretary has the right to change the venue and timing of the matches keeping in view the local situations/conditions.
2. The information brochure is attached with the fixtures.

KURUKSHETRA UNIVERSITY KURUKSHETRA

(Established by the State Legislature Act XII of 1956)

('A+' Grade, NAAC Accredited)

Directorate of Sports

North Zone Inter University Cricket (Men) Championship, 2022-23

(From 23rd February to 04th March, 2023)

INFORMATION BROCHURE

1. Reception

- ✓ Participating teams shall intimate or report to the Secretary about the date and time of their arrival, well in advance.
- ✓ Kurukshetra is at a distance of about 160 Kms. from Delhi, on Delhi-Panipat-Karnal Ambala route on the Northern Railway. It is about 35 Kms. from Ambala towards Karnal. A good number of trains (Mail as well as passenger) run from New Delhi to Amritsar/JammuTawi/Ambala, and Kurukshetra is on this route. Teams coming by Bus can alight at Pipli Bus Stand, which is just 08 Kms. from Kurukshetra University. Frequent local Bus service and Auto Rickshaws from Pipli are available from early morning till late night.

2. Accomodation

Teams will be provided free unfurnished rooms type of accommodation near the University Campus in Dharamshala(s). Teams are requested to bring their own Locks & Keys for their own safety. **Accommodation will be provided only 24 hours prior to the commencement of the matches and the same is required to be vacated immediately if they fail to qualify for the next round.**

- ✓ Accommodation counter will be arranged at Kurukshetra University. All the team managers are requested to contact **Sh. Ramesh Chand** -9416833605 & **Sh. Rajesh Kumar** - 9354920309 the accommodation in-charges at the tournament venue.
- ✓ Each team will have to pay Rs. 2000/- (Rupees Two Thousand Only) as caution deposit, which will be refunded at the time of departure of the team after adjusting to the cost of damages.

3. Manager's Meeting

The meeting of the Managers will be held on **22nd February, 2023 at 04:00 PM** in the University Campus. All team managers are requested to be present.

4. Eligibility & Documents

The team Managers are requested to bring with them 04 Copies of Eligibility proforma (Latest Proforma with **Aadhar** Number of the Players) duly typed and signed by the Registrar / Director of Physical Education / Sports officer of the participating University, sports Identity Card, DMC of Matric and 10+2 (in case of under Graduate classes) and that of Matric, 10+2 and Graduation (in case of P.G. classes) & a copy of subscription receipt obtained from AIU New Delhi. **The teams must also bring with them the Online Generated receipt of AIU Registration Fee @ Rs. 3,000/- per Team.** The link for submitting online Fee is <https://payment.aiu.ac.in> The manual for generating online is also attached.

5. Officiating Charges

- ✓ The Manager of every team should pay Rs. 1500/- (Rupees One thousand Five Hundred Only) per match as Officiating charges to the organizing Secretary / Ground In-charge officers before the commencement of their match.
- ✓ An amount of Rs.1000/- (Rupees one Thousand Only) will be collected towards the match ball. The ball will be supplied by the organizing committee. No other ball will be allowed in the tournament.
- ✓ Matches will be held on matting and turf as per the availability of grounds. Hence the teams are advised to play accordingly.
- ✓ The teams should be ready Forty five minutes before the Commencement of their matches.
- ✓ The Managers / Coach will be requested to produce the ball receipt whenever asked by the umpire.

6. Competition Rule

- ✓ All matches will be played as per the International Cricket Council as adapted by Association of Indian Universities (AIU), New Delhi.
- ✓ The team Managers are requested to follow the match schedule strictly and arrange to report to their teams at least 30 minutes before the commencement of the match.
- ✓ **The organizing Secretary reserves the right to make any changes in the programs and the venue, if necessary, which shall be final and binding on the participant teams.**
- ✓ A copy of the fixtures is enclosed.
- ✓ The team Managers, Coaches and players are requested to cooperate with the Organizing Secretary/Organizers/Match Officials for the smooth conduct of the tournament.
- ✓ Protest against any other nature in connection with conduct of sporting competitions shall be in writing and must reach the organizing secretary along with protest fee Rs.2000/- only within "Two Hours" of the conclusion of the concerned matches for consideration of the "Jury of Appeal" for an appropriate necessary action, then and there/on the spot, in this regard.

7. PLAYING CONDITION-25 OVERS-UPTO QUARTER FINALS

- ✓ All matches are played on Knock-out Basis.
- ✓ A player should be in proper cricketing attire (White clothing & predominantly white shoes unless specified otherwise). The umpires are the sole authority in implementing the dress code. The Umpires shall ask the concerned player to leave the field if the dress code is not followed.
- ✓ On matting wickets use of spiked shoes by the bowlers and batsman is not permitted.
- ✓ All matches will be of one innings per side, each innings being limited to 25 Overs per side. Minimum 10 overs constitute a match in case of any interrupted matches.
- ✓ Declaration is not permitted.
- ✓ No bowler shall bowl more than 05 overs in an innings. In a delayed or interrupted match where the overs are reduced for both teams or for the team bowling second, no bowler may bowl more than one-fifth of the total overs allowed. Where the total overs are not divisible by 05, one additional over shall be allowed to the maximum number per bowler necessary to make up the balance.
- ✓ Free hit will be awarded for all types of No Balls. During free hit, chance of field/fieldman is not permitted for the same striker.
- ✓ At the instant of delivery, there shall not be more than 5 field men outside the inner circle throughout the match.

- ✓ A bowler shall be limited to One fast short-pitched delivery per over. Subsequent short pitch deliveries in the same over shall be called No Ball
- ✓ Hour of Play

Match:	08:00 am -12:00 Noon	First session
	12:00pm -2:15pm	Lunch
	02:30pm -06:30pm	Second Session

8. RESULT-25 OVERS-UPTO QUARTER FINALS

- ✓ Once the match begins and a team does not continue with the it shall be considered as conceding the match.
- ✓ Absenting a team or only certain number of players present and not filling the nomination form is considered as "Walk Over".
- ✓ When the match is called off without a ball being bowled and even minimum 10 overs for both the sides is not achieved the result will be decided by "SPIN OF COIN" by the captains in the presence of umpires.
- ✓ In case of a tie, the team which has lost a lesser number of wickets will be declared as the winner.
- ✓ In case of equality in the number of wickets lost, the result will decided by " SPIN COIN" by the captains in presence of the umpires.
- ✓ In case of team batting second has the opportunity of playing 10 overs or more and is interrupted due to ground, weather and light conditions the result of the match is decided with the team having better run rate at that stage. (For Ex. If team A has scored 150 runs in allotted 25 overs (NRR=6.00), Team B had scored 100 runs in 20 overs (NRR=5.00). Team A wins the match by better Run rate.
- ✓ Umpire's decision will B final and binding. No appeal/protest against the umpire's decision are entertained.

NOTE: ALL TEAMS SHOULD REPORT TO THE GROUND 30 MINUTES BEFORE THE SCHEDULED TIME FOR THE START OF THE MATCH

9. PLAYING CONDITION-40 OVERS

- ✓ All Matches are played on Knockout Basis.
- ✓ A player should be in proper cricketing attire (white clothing & predominantly white shoes unless specified otherwise). The umpires are the sole authority in implementing the dress code. The Umpires shall ask the concerned player to leave the field if the dress code is not permitted.
- ✓ On matting wickets use of spiked shoes by the bowlers and batsman is not permitted.
- ✓ All matches will be of one innings per sside, each innings being limited to 40 Overs per side. Minimum 10 overs constitute a match in case of any interrupted matches.
- ✓ Declaration is not permitted.
- ✓ No bowler shall bowl more than 08 overs in an innings. In a delayed or interrupted match where the overs are reduced for both teams or for the team bowling second, no bowler may bowl more than one-fifth of the total overs allowed. Where the total overs are not divisible by 5, one additional over shall be allowed to the maximum number per bowler necessary to make up the balance.
- ✓ Free hit will be awarded for all types of No Balls. During Free hit, change of field/fieldman is not permitted for the same striker.
- ✓ Field placement during power play will be as under:

- 01 to 08 overs -- 02 fielders outside the inner circle
 - 09 to 32 overs – 04 fielders outside the inner circle
 - 33 to 40 overs – 05 fielders outside the inner circle
- ✓ If the number of overs are reduced for the match, power play overs will be accordingly reduced by the umpires and will be informed to both captains at the toss.
 - ✓ A bowler shall be limited Two fast short-pitched delivery per over. Subsequent short pitch deliveries in the same over shall be called No Ball
 - ✓ Hours of Play

Match:	08:00 am -12:00 Noon	First Session
	12:00pm -2:15pm	Lunch
	02:30pm -06:30pm	Second Session

10. RESULT

- ✓ Once the match begins and a team does not continue with the match it shall be considered conceding the match.
- ✓ Absenting a team or only a certain number of players present and not filling the nomination form is considered as "Walk over".
- ✓ When the match is called off without a ball being bowled and even minimum 15 overs for both sides is not achieved the result will be decided by "SPIN OF COIN" by the captains in the presence of umpires.
- ✓ In case of a tie, the team which has lost, the result will be decided by "SPIN OF COIN" by the captains in presence of the umpires.
- ✓ In case the team batting second has the opportunity of playing 10 overs or more and is interrupted due to ground, weather and light conditions the result of the match is decided with the team having better net run rate at that stage. (For Ex. If team A has scored 270 runs in allotted 45 overs (NRR=6.00), Team B had scored 150 runs in 30 overs(NRR=5.00). team A wins the match by better Run rate.
- ✓ Umpire's decision will be final and binding. No appeal/protest against the umpire's decision are entertained.

NOTE: ALL TEAMS SHOULD REPORT TO THE GROUND 30 MINUTES BEFORE THE SCHEDULED TIME FOR THE START OF THE MATCH

 Organizing Secretary

Kurukshehra University Kurukshehra

Directorate of Sports

All India Inter University Cricket (Men) Championship 2022-23

(20th to 27th April, 2023)

FIXTURES

<u>Pool 'A'</u>		<u>Pool 'B'</u>		<u>Pool 'C'</u>		<u>Pool 'D'</u>	
1. Kurukshehra Uni. (N-1)		1. University of Madras (TN) (S-1)		1. Pt. DDU Shekhawati Uni, (W-1)		1. VBSPU Jaunpur (E-1)	
2. Sarvjanik Uni, Surat (W-2)		2. ABV Uni, Bilaspur (CG) (E-2)		2. MD University, Rohtak (N-2)		2. Bharathiar University, TN (S-2)	
3. Kolhan Uni, Jharkhand (E-3)		3. Panjab Uni, Chandigarh (N-3)		3. University of Calicut (S-3)		3. KBC NM Uni, Jalgaon (W-3)	
4. Reva Uni, Karnataka (S-4)		4. University of Mumbai (W-4)		4. Tripura Uni, Agartala (E-4)		4. GNDU Amritsar (N-4)	

Date: 20.04.2023

<u>Match</u>	<u>Team</u>	<u>VS</u>	<u>Team</u>	<u>Time</u>	<u>Pool</u>	<u>Ground</u>
1.	Kurukshehra University		Reva University, Karnataka	10:00 AM	A	G-1
2.	University of Madras		University of Mumbai	10:00 AM	B	G-3
3.	VBSP University, Jaunpur		GNDU Amritsar	10:00 AM	D	G-4
4.	PDU Shekhawati, Sikar		Tripura University, Agartala	10:00 AM	C	G-2
5.	Sarvjanik University, Surat		Kolhan University, Jharkhand	02:00 PM	A	G-4
6.	Panjab University, Chandigarh		ABV University, Bilaspur	02:00 PM	B	G-2
7.	MD University, Rohtak		University of Calicut	02:00 PM	C	G-1
8.	Bharathiar Uni, Tamil Nadu		KBC NM University, Jalgaon	02:00 PM	D	G-3

Date: 21.04.2023

<u>Match</u>	<u>Team</u>	<u>VS</u>	<u>Team</u>	<u>Time</u>	<u>Pool</u>	<u>Ground</u>
9.	Kurukshehra University		Kolhan University, Jharkhand	07:00 AM	A	G-2
10.	University of Madras		Panjab University, Chandigarh	07:00 AM	B	G-1
11.	PDU Shekhawati, Sikar		University of Calicut	07:00 AM	C	G-4
12.	Sarvjanik University, Surat		Reva University, Karnataka	07:00 AM	A	G-3
13.	VBSP University, Jaunpur		KBC NM University, Jalgaon	02:00 PM	D	G-2
14.	ABV University, Bilaspur		University of Mumbai	02:00 PM	B	G-4
15.	MD University, Rohtak		Tripura University, Agartala	02:00 PM	C	G-3
16.	Bharathiar Uni, Tamil Nadu		GNDU Amritsar	02:00 PM	D	G-1

Date: 22.04.2023

Match	Team	VS	Team	Time	Pool	Ground
17.	Kurukshetra University		Sarvjanik University, Surat	07:00 AM	A	G-1
18.	University of Calicut		Tripura University, Agartala	07:00 AM	C	G-2
19.	University of Madras		ABV University, Bilaspur	07:00 AM	B	G-3
20.	VBSP University, Jaunpur		Bharathiar Uni, Tamil Nadu	07:00 AM	D	G-4
21.	Kolhan University, Jharkhand		Reva University, Karnataka	02:00 PM	A	G-3
22.	PDU Shekhawati, Sikar		MDU Rohtak	02:00 PM	C	G-1
23.	Panjab University, Chandigarh		University of Mumbai	02:00 PM	B	G-4
24.	GNDU Amritsar		KBC NM University, Jalgaon	02:00 PM	D	G-2

Note:

1. Fixtures for Knock-out matches will be circulated after the completion of league matches.
2. Organising Secretary reserves the right to change the timings, court and venue of the matches in view of the situation.

Ground No. 01	University Sports Complex
Ground No. 02	University Senior Model School
Ground No. 03	SKS College, Kirmich
Ground No. 04	Cricket Ground, Samana Bahu

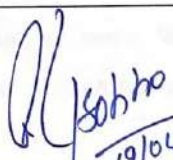
19/04/2023
Organizing Secretary



KURUKSHETRA UNIVERSITY KURUKSHETRA
(Established by the State Legislature Act XII of 1956)
(*A+* Grade, NAAC Accredited)



Dr. Rajesh Sobti
Director Phy. Edu. & Sports
& Secretary, K.U. Sports Council

Phones: Office. 01744-238074
Mob. No. 9467054670
Email: kuksports@gmail.com

No. Sports/23/ 742
Dated 03/04/2023

To

The Registrar/DirectorSports/SportsOfficer/Secretary Sports Committee/
Council of the Universities qualified for All India Inter University Cricket (M) Champ 2022-23

Subject: **All India Inter University Cricket (Men) Championship (Rohinton Baria Trophy) 2022-23**

Sir/Madam,

Kindly refer to the undersigned office email dated 20th March, 2023 vide which the All India Inter University Cricket (Men) championship 2022-23 was postponed due to bad weather conditions.

We are happy to inform you that the All India Inter University Cricket (Men) Championship (Rohinton Baria Trophy) 2022-23 is now scheduled to be held from **20th to 27th April, 2023**. On behalf of the Hon'ble Vice-Chancellor, Sports Council, Organizing Committee and the students of Kurukshetra University, we have great pleasure to invite the team of your esteemed University to this prestigious championship **(Rohinton Baria Trophy) 2022-23** to be organized at Kurukshetra University. The schedule of the Championship is as under:-

Sr.	Tournament	Dates of Tournament
1.	All India Inter University Cricket (Men) Champ. 2022-23	20 th to 27 th April, 2023

I extend a very cordial welcome to your team to participate in this Championship at the Holy City.

General Instructions:-

1. A meeting of the Managers and Coaches of the teams will be held on **19th April, 2023 at 05:00 p.m.** at the venue of the tournament.
2. The competition will be conducted as per latest rules of International Cricket Council as adopted by BCCI & Association of Indian Universities.
3. The decision of the Organizing Committee will be final & binding.
4. The team Managers are requested to bring with them the attested copy of the Eligibility proforma (attested from the organizing University of zonal championship), sports Identity Card, DMC of Matric and 10+2 (in case of under Graduate classes) and that of Matric, 10+2 and Graduate (in case of P.G. classes) duly attested by the competent authority of their Universities and organising Secretary of the respective zone.
5. The team managers are requested to bring with them the proof of the AIU Sports Registration fee of Rs. 3,000/- submitted online.

6. Participating teams are requested to bring with them their own locks etc. Carpets (Darries) will be provided at the place of lodging. Managers will have to deposit Rs. 2,000/- as security, which will be refunded after the return of material issued by this office.
7. Officiating charges will be charged as per AIU rules.
8. Weather at Kurukshetra in the month of April will be **mild hot**. Only unfurnished accommodation will be provided. The bedding will be provided on payment basis.
9. **Teams will bring with them their University Flag for the March Past. Participation of the teams in the March Past is essential otherwise the teams will not be allowed to participate in the Championship.**
10. In case of any difficulty, participating Universities may contact the following:-
 - Sh. Ramesh Chand -9416833605 & Sh. Rajesh Kumar – 9354920309 for accommodation
 - Sh. Sanjeev Kapoor - 9896513793 for transportation
11. The Organising Secretary reserves the rights to change the venue & timing of the matches.

As Kurukshetra is 'Holy City' so liquor and Non Vegetarian meals are strictly prohibited within the jurisdiction of 'Dharmakshetra'.

Once again, I extend a cordial welcome to your team to participate in these Championship.

With regards,

08/04/2023
Organizing Secretary
AIU Cricket (M) Championship 2022-23.

C.C:

1. Dr. Baljit Singh Sekhon, Joint Secretary Sports, AIU, New Delhi for kind information.
2. President & Vice-President, K.U. Sports Council for kind information.
3. O.S.D. to Vice-Chancellor for kind information.
4. P.S. to Vice-Chancellor/Registrar (for kind information of the Vice Chancellor/ Registrar)
5. Director, Public Relations, KUK for kind information and necessary action.



KURUKSHETRA UNIVERSITY KURUKSHETRA

(Established by the State Legislature Act XII of 1956)

('A+' Grade, NAAC Accredited)



Phones: Office. _ 01744-238074

Mob. No . 9467054670

Email: kuksports@gmail.com

Dr. Rajesh Sobti
Director Phy. Edu. & Sports
& Secretary, K.U. Sports Council

No. Sports/23/ 486
Dated 25.02.2023

To

The Registrar/DirectorSports/SportsOfficer/Secretary Sports Committee/
Council of the Member Universities.

Subject: **North Zone Inter University Handball (Men) Championship 2022-23**

Sir/Madam,

On behalf of the Hon'ble Vice-Chancellor, Sports Council, Staff Members, the Management Committee and the students of Kurukshetra University, it gives me immense pleasure in welcoming you to the North Zone Inter University Handball (Men) Championship 2022-23 to be organized at Kurukshetra University. The schedule of the Championship is as under:-

Sr.	Tournament	Dates of Tournament
1.	North Zone Inter University Handball (Men) Champ. 2022-23	10 th to 14 th March, 2023

On behalf of Kurukshetra University, I extend a very cordial welcome to your team to participate in this Championship at the Holy City.

General Instructions:-

1. A meeting of the Managers and Coaches of the teams will be held on **09th February** at **04:00 p.m.** at the venue of the tournament.
2. The competition will be conducted as per latest rules of International Handball Federation as adopted by Handball Federation of India & Association of Indian Universities.
3. The decision of the Organizing Committee will be final & binding.
4. The team Managers are requested to bring with them 04 Copies of Eligibility proforma (Latest Proforma with Aadhar Number of the Players), sports Identity Card, DMC of Matric and 10+2 (in case of under Graduate classes) and that of Matric, 10+2 and Graduate (in case of P.G. classes) duly attested by the competent authority of their Universities and organising Secretary of the respective zone.

5. The teams must also bring with them the Online Generated receipt of AIU Registration Fee @ Rs. 3,000, Team.
6. Participating teams are requested to bring with them their own locks etc. Carpets (Darries) will be provided at the place of lodging. Managers will have to deposit Rs. 2,000/- as security, which will be refunded after the return of material issued by this office.
7. Officiating charges will be charged as per AIU rules.
8. Weather at Kurukshetra in the month of March will be moderate. As such, the participants and officials are requested to bring with them sufficient warm clothes and bedding as only unfurnished accommodation will be provided.
9. Teams will bring with them their University Flag for the March Past. Participation of the teams in the March Past is essential otherwise the teams will not be allowed to participate in the Championship.
10. In case of any difficulty, participating Universities may contact the following:-
 - Sh. Ramesh Chand -9416833605 & Sh. Rajesh Kumar – 9354920309 for accommodation
 - Sh. Sanjeev Kapoor - 9896513793 for transportation
11. The Organising Secretary reserves the rights to change the venue & timing of the matches.
12. **No accommodation will be provided before 24 Hours of the Start of the First Match and after 24 Hours after Completion of the Last Match.**

As Kurukshetra is 'Holy City' so liquor and Non Vegetarian meals are strictly prohibited within the jurisdiction of 'Dharmakshetra'.

Once again, I extend a cordial welcome to your team to participate in these Championship.

With regards,

Encl:

- i. Fixtures & Information Brochure
- ii. Manual for AIU Registration Fee

Organizing Secretary
NZIU Handball (M) Championship 2022-23.

C.C:

1. Dr. Baljit Singh Sekhon, Joint Secretary Sports, AIU, New Delhi for kind information.
2. President & Vice-President, K.U. Sports Council for kind information.
3. O.S.D. to Vice-Chancellor for kind information.
4. P.S. to Vice-Chancellor/Registrar (for kind information of the Vice Chancellor/ Registrar)
5. Director, Public Relations, KUK for kind information and necessary action.



KURUKSHETRA UNIVERSITY KURUKSHETRA

(Established by the State Legislature Act XII of 1956)

('A+' Grade, NAAC Accredited)

Directorate of Sports

Fixtures for North Zone Inter University Handball (Men) Championship, 2022-23

(From 10th to 14th March, 2023)

POOL-A

Kurukshetra University, Kurukshetra (LYRU)

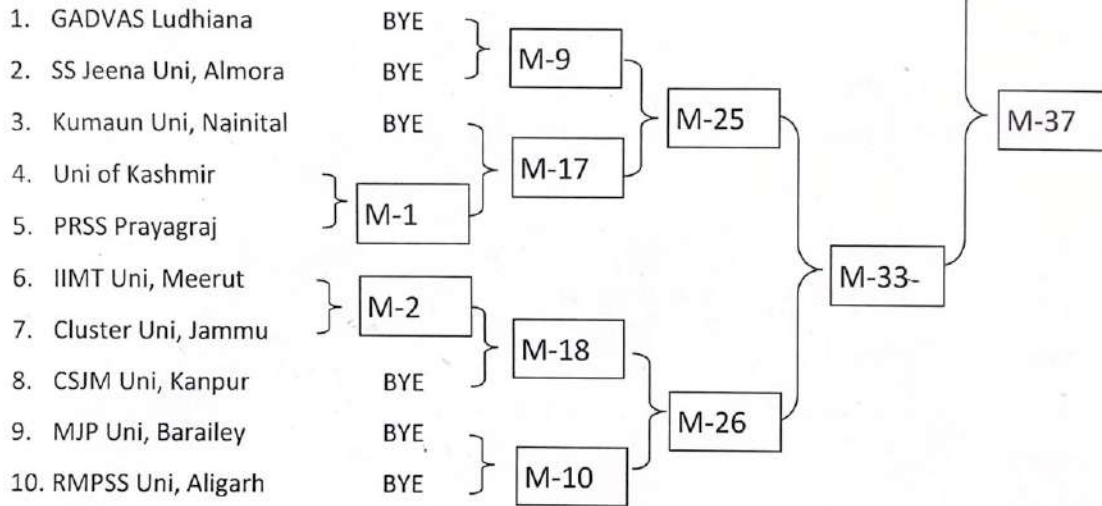

POOL-B

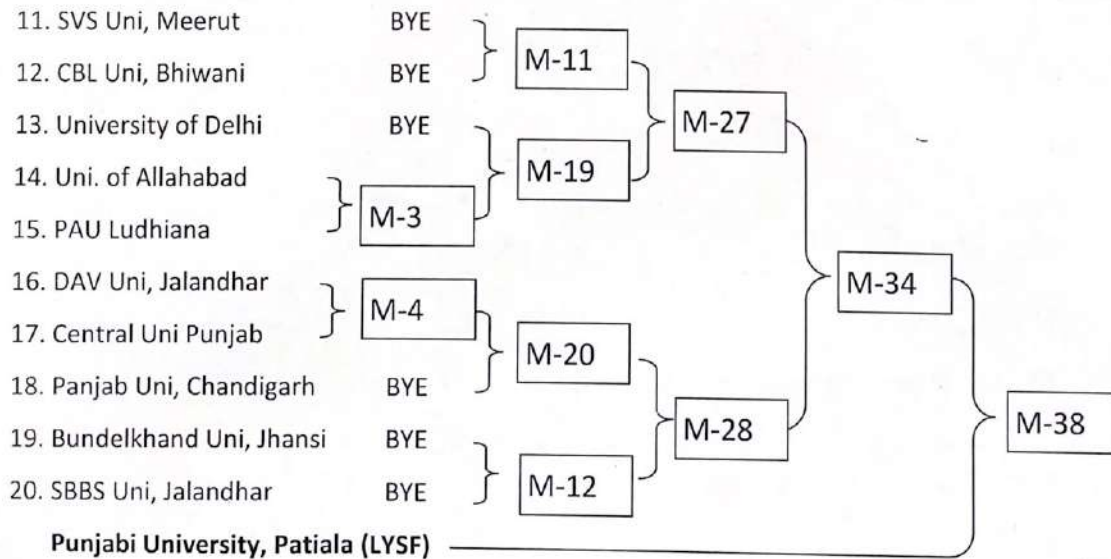

POOL-C

Guru Jambheshwar University Hisar (LYSF)

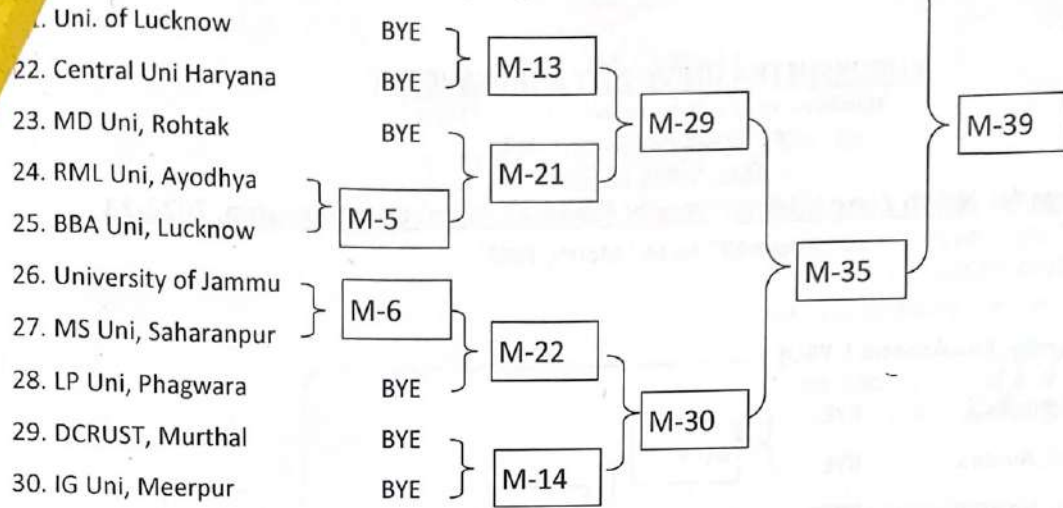

POOL-D

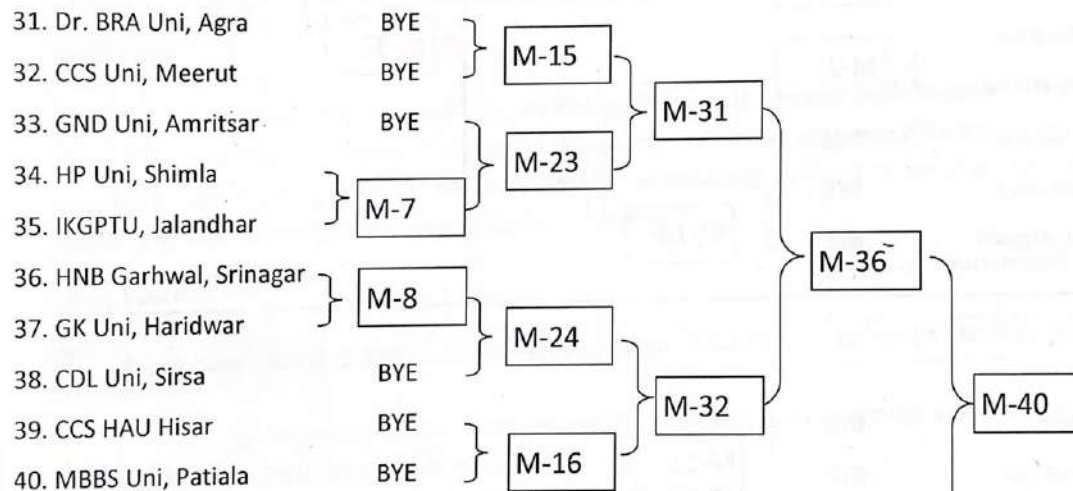

CRS University, Jind (LYW)

The schedule of the matches is as under:

10 th March, 2023	M-01	to	M-16	
11 th March, 2023	M-17	to	M-32	
12 th March, 2023	Pre Q.F. & Q.F.	M-33	to	M-40

The League matches will be played on 13th & 14th March, 2023, and the fixtures for the same will be circulated after the quarter final matches.

[Handwritten Signature]
Organizing Secretary



KURUKSHETRA UNIVERSITY KURUKSHETRA

(Established by the State Legislature Act XII of 1956)

('A+' Grade, NAAC Accredited)



Phones: Office. 01744-238074

Mob. No. 9467054670

Email: kuksports@gmail.com

Dr. Rajesh Sobti
Director Phy. Edu. & Sports
& Secretary, K.U. Sports Council

No. Sports/23/ 567
Dated 13/03/2023

To

The Registrar/DirectorSports/SportsOfficer/Secretary Sports Committee/
Council of the Universities qualified for All India Inter University Handball (M) Champ 2022-23

Subject: **All India Inter University Handball (Men) Championship 2022-23**

Sir/Madam,

On behalf of the Hon'ble Vice-Chancellor, Sports Council, Staff Members, the Management Committee and the students of Kurukshestra University, it gives me immense pleasure in welcoming you to the All India Inter University Handball (Men) Championship 2022-23 to be organized at Kurukshestra University. The schedule of the Championship is as under:-

Sr.	Tournament	Dates of Tournament
1.	All India Inter University Handball (Men) Champ. 2022-23	16 th to 20 th March, 2023

On behalf of Kurukshestra University, I extend a very cordial welcome to your team to participate in this Championship at the Holy City.

General Instructions:-

1. A meeting of the Managers and Coaches of the teams will be held on **15th March, 2023 at 05:00 p.m.** at the venue of the tournament.
2. The competition will be conducted as per latest rules of International Handball Federation as adopted by Handball Federation of India & Association of Indian Universities.
3. The decision of the Organizing Committee will be final & binding.
4. The team Managers are requested to bring with them 04 Copies of Eligibility proforma (Latest Proforma with Aadhar Number of the Players), sports Identity Card, DMC of Matric and 10+2 (in case of under Graduate classes) and that of Matric, 10+2 and Graduate (in case of P.G. classes) duly attested by the competent authority of their Universities and organising Secretary of the respective zone.
5. Participating teams are requested to bring with them their own locks etc. Carpets (Darries) will be provided at the place of lodging. Managers will have to deposit Rs. 2,000/- as security, which will be refunded after the return of material issued by this office.
6. Officiating charges will be charged as per AIU rules.

7. Weather at Kurukshetra in the month of March will be **moderate**. As such, the participants and officials are requested to bring with them sufficient warm clothes and bedding as only unfurnished accommodation will be provided.
8. Teams will bring with them their University Flag for the March Past. Participation of the teams in the March Past is essential otherwise the teams will not be allowed to participate in the Championship.
9. In case of any difficulty, participating Universities may contact the following:-
- Sh. Ramesh Chand -9416833605 & Sh. Rajesh Kumar – 9354920309 for accommodation
 - Sh. Sanjeev Kapoor - 9896513793 for transportation
10. The Organising Secretary reserves the rights to change the venue & timing of the matches.
11. **No accommodation will be provided before 24 Hours of the Start of the First Match and after 24 Hours after Completion of the Last Match.**

As Kurukshetra is 'Holy City' so liquor and Non Vegetarian meals are strictly prohibited within the jurisdiction of 'Dharmakshetra'.

Once again, I extend a cordial welcome to your team to participate in these Championship.

With regards,



Organizing Secretary
All India Handball (M) Championship 2022-23.

Encl:

C.C:

1. Dr. Baljit Singh Sekhon, Joint Secretary Sports, AIU, New Delhi for kind information.
2. President & Vice-President, K.U. Sports Council for kind information.
3. O.S.D. to Vice-Chancellor for kind information.
4. P.S. to Vice-Chancellor/Registrar (for kind information of the Vice Chancellor/ Registrar)
5. Director, Public Relations, KUK for kind information and necessary action.



































①

DEAN STUDENTS' WELFARE
KURUKSHETRA UNIVERSITY KURUKSHETRA
(Established by the State Legislature Act XII of 1956)
("A" Grade, NAAC Accredited)

No. DSW/23 / 326-328
Dated: 19/1/2023

To

The Director, UIET,
The Principal, IIHS,
The Principal, ITTR,

Sub: -Rostrum:2022-23 (Annual Public Speaking Competitions) Round-I.

Kurukshetra University organizes the Public Speaking Competitions 'ROSTRUM' every year. The competitions are organized in three stages:

- a) Stage-I at University Teaching Departments/Institutes level.
- b) Stage-II at Faculty level.
- c) Final Stage-III at University level.

Topics for the three stages of the competition are provided separately and the same are uploaded on the University Website (www.kuk.ac.in). Winners of the first stage will compete at the stage-II and consequently the winners of Stage-II will compete in the final stage of the competition at the University level.

It may please be noted that as per past practice Ist Round competition of Rostrum event will be organized by Principal IIHS, Principal ITTR and Director UIET themselves **latest by Feb. 10, 2023** out of their respective Amalgamated Fund. However, the topics and guidelines will remain the same as mentioned for UTD. The expenses on the event organization and prize money to the winners of the Round Ist shall be met by the Institutes themselves and Principal, IIHS; Principal, ITTR and Director, UIET will recommend the names of Ist 12, 3 and 10 prize winning students respectively for participation in the IInd round of competition which will be organized by DSW office. **The names of the Teacher Coordinator, 02 Teacher Judges, 01 Student Comperer, 01 Student Judge and first three winners of the competition are to be sent to the Dean Students' Welfare Office on the enclosed Proforma latest by Feb. 11, 2023.** Stage-II of the competitions will be organized in the month of Feb., 2023 and the exact schedule will be intimated through e-mail to the Chairpersons/Directors. It would be the responsibility of the winner students of Stage-I to stay in touch with DSW office.

Following are enclosed herewith:-

1. Guidelines for the competition
2. List of Topics for the Stage-I competition
3. Proforma for results
4. Proforma for attendance of student speakers

For further clarifications, please contact:

1. Prof. Omvir Singh, Dept. of Geography (Coordinator) Mb. 94670-54590.
2. Dr. Archana Chaudhry, (Dept. of Economics) (Joint Coordinator) Mb-98965-37107.

Dean Students' Welfare

Endst. No.-DSW/23/ 329-330

Dated: 19/1/2023

1. OSD to the Vice-Chancellor for kind information of the Vice-Chancellor.
2. P.A to the Registrar, for kind information of the Registrar.

19/1/2023
Dean Students' Welfare

2

DEAN STUDENTS' WELFARE
KURUKSHETRA UNIVERSITY KURUKSHETRA
(Established by the State Legislature Act XII of 1956)
("A" Grade, NAAC Accredited)

No. DSW/23 275-323
Dated: 19/1/2023

To

All Chairpersons, University Teaching Departments,
Director, Institute of Law,
Director, Institute of Management Studies,
Director, Institute of Pharmacy,
Director, Institute of Mass Communication & Media Technology,
Director, Institute of Environmental Studies,
Coordinator, Rostrum:2022-23
Joint Coordinator, Rostrum:2022-23

Sub: - Rostrum:2022-23 (Annual Public Speaking Competitions) Round-I.

Kurukshetra University organizes the Public Speaking Competitions 'ROSTRUM' every year. The competitions are organized in three stages:

- Stage-I at University Teaching Departments/Institutes level.
- Stage-II at Faculty level.
- Final Stage-III at University level.

Topics for the three stages of the competition are provided separately and the same are uploaded on the University Website (www.kuk.ac.in). Winners of the first stage will compete at the stage-II and consequently the winners of Stage-II will compete in the final stage of the competition at the University level.

As per past practice, Chairpersons/Directors are to organize the competitions at the Deptt./Instt. level latest by Feb. 10, 2023. The names of the Teacher Coordinator, 02 Teacher Judges, 01 Student Comperer, 01 Student Judge and first three winners of the competition are to be sent to the Dean Students' Welfare Office on the enclosed Proforma latest by Feb. 11, 2023. Stage-II of the competitions will be organized in the month of Feb., 2023 and the exact schedule will be intimated through e-mail to the Chairpersons/Directors. It would be the responsibility of the winner students of Stage-I to stay in touch with DSW office.

Following are enclosed herewith:-

- Guidelines for the competition
- List of Topics for the Stage-I competition
- Proforma for results
- Proforma for attendance of student speakers

For further clarifications, please contact:

- Prof. Omvir Singh, Dept. of Geography (Coordinator) Mb. 94670-54590.
- Dr. Archana Chaudhry, (Dept. of Economics) (Joint Coordinator) Mb-98965-37107.

Dean Students' Welfare

Endst. No.-DSW/23/ 324-325

Dated: 19-1-2023

- OSD to the Vice-Chancellor for kind information of the Vice-Chancellor.
- P.A to the Registrar, for kind information of the Registrar.



Dean Students' Welfare

-3-

ROSTRUM-2022-23 (Round-I)

Guidelines for Department/Institute/UIET Level Competitions (Round-I)

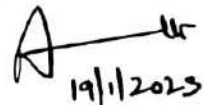
1. All regular students of University Teaching Departments/Institutions on the campus including M Phil. Students can participate. The students enrolled for Ph.D, or pursuing pre-Ph.D. course shall not be eligible for participation.
2. The presentation will be of 3 to 5 minutes. Paper reading will not be allowed.
3. Medium of speech can be either English or Hindi. At Stage-I, students of Department of Punjabi and Sanskrit can speak in Punjabi and Sanskrit language respectively. However, at Stages II & III of the competition, the medium of speech shall either be English or Hindi.
4. The topics must be circulated and displayed on the notice boards by the concerned Deptt./Instt./College.
5. All Chairpersons/Directors/Principals will nominate two teachers from their own or other Departments to be associated as Judges for the Department level competitions. In addition, Chairpersons/Directors/Principals will also nominate one student to the Judges panel thereby providing three Judges for all Department/Institute level competitions.
6. Chairpersons/Directors/Principal will also nominate one student to compere and one teacher to Co-ordinate the Stage-I level competitions. As such, this competition will mainly be a student activity.
7. Teachers associated as Judges & Coordinator at the Deptt./Instt. Level, will be paid an honorarium of Rs. 500/- and students associated as Judges and comperers will be paid Rs.400/- each.
8. In case the number of speaker students is upto 4, then only one prize should be awarded; and if the number of speaker students is upto 6, then two prizes should be awarded; and finally if the number of speaker students is seven and above, then only the number of prizes will be three. All Teacher Co-ordinators are requested to send the attendance of the speaker students along with result performa. No results will be entertained without attendance of the speaker students.
9. Where the number of the students are more as in case of Dept. Law , Inst. of Law, Inst. of Management Studies, IMC & MT, Inst of Pharmacy, the number of prizes shall be two each for 1st, 2nd, & 3rd positions without violating the spirit of point No.8 above.
10. In case of IHS, ITTR and UIET, the competition of Stage-I will be organized at their own level and expenses including prize money at level Ist, so occur, will be met out of their respective A/Funds. These institutions will recommend first ten, twelve and three students respectively for participation at Stage-II of the Rostrum which is to be held at University level in the month of 2023.
11. A cash prize of Rs.1,000/- Rs. 750/- and Rs. 500/- (Ist, IInd and IIIrd) will be given to the winning students along with a certificate.
Note: Only one student will be considered each for 1st, 2nd and 3rd Position. No parallel/(bracketed) prizes will be entertained in any case.
12. Results of the Round-I competitions must be returned by the teacher Co-ordinator through their respective Chairperson/Director/Principal duly filled on the enclosed proforma latest by 11.02.2023 to the office of DSW.

19/1/2023

Dean Students' Welfare

**DEAN STUDENTS' WELFARE
ROSTRUM-2022-23
Round - I**

List of Topics

- 1. Importance of Agniveer Scheme in Defence Sector and Challenges Ahead**
- 2. G-20: Its Role in World Economy, Polity and Society**
- 3. Prospects of NEP-2020**
- 4. Mera Pani, Meri Virasat**
- 5. Role of Bhagwad Gita in Conflict Resolution**
- 6. Media Trials : Pros and Cons**
- 7. AatmaNirbhar Bharat: How Close are We towards Employment Generation?**
- 8. AKAM: India's Journey of Development since Independence**

Dean Students' Welfare

Note: The speakers must adhere to the spirit of the topic while translating it from English to Hindi and vice-versa.

19/1/2023

-5-

ROSTRUM:2022-23
Annual Public Speaking Competition
Results Round-I

Proforma to be completed by all Chairpersons/Directors of Deptt/Institutes/Principal (ITTR & IHS) and returned to the O/o Dean Students' Welfare by **Feb. 11, 2023**.

Name of the Deptt./Instt. **Date of Competition** **Time** **Venue**

Name of the Teacher Coordinator	Mobile No.	Name of the Bank branch (City) with IFSC Code	Account No.

Name of the Teacher Judges	Class/Roll No.	Name of the Bank branch (City) with IFSC Code	Account No.
1			
2			

Name of the winners with mobile No.	Class/Roll No.	Name of the Bank branch (City) with IFSC Code	Account No.
1			
2			
3			

Name of Student Comperer	Class/Roll No.	Name of the Bank branch (City) with IFSC Code	Account No.

Name of Student Judge	Class/Roll No.	Name of the Bank branch (City) with IFSC Code	Account No.

Total number of Students Speakers _____
(as per attendance proforma)

Total number of Students who attended the event _____

Total number of Teachers who attended the event _____

Chairperson/Director/Principal
(Signature with Seal)

19/11
A
19/11/2023

ROSTRUM:2022-23
Annual Public Speaking Competition
Round-I
Attendance Proforma of Student Speakers

Attendance Proforma to be sent along with results. Results will not be considered without attendance proforma in any case.

Name of the Deptt./Instt. _____

Sr. No.	Name of the student	Class	Roll No.	Medium of Speech	Topic of the Student Speaker	Signatures of the Student

Total number of Student Speakers _____
(as per attendance proforma)

Total number of Students who attended the event _____

Signature of the Teacher Co-ordinator _____

Principal/Chairperson/Director
(Signature)

A
19/11/2023

-7-

DEAN STUDENTS' WELFARE
KURUKSHETRA UNIVERSITY KURUKSHETRA
(Established by the State Legislature Act XII of 1956)
(‘A+’ Grade, NAAC Accredited)

No. DSW/2023/336-385
Dated: 8/2/2023

To



All the **Chairpersons**, UTD,
Director, Institute of Law,
Director, Institute of Management Studies,
Director, Institute of Pharmacy,
Director, IMC & MT,
Director, Institute of Evs. Studies,
Coordinator, Rostrum: 2022-23
Joint Coordinator, Rostrum: 2022-23

Sub: Rostrum : 2022-23 (Annual Public Speaking Competitions) Round-I.

This is in continuation of our earlier office dispatch No. DSW/23/275-323 dated 19.01.2023 on the subject cited above, vide which the Chairpersons/Directors are requested to organize the competitions at Deptt./Inst. level latest by Feb. 10, 2023.

In this regard, several requests has been received from the Deptt./Inst. to extend the date of competition as the students are busy in their final exams./practical.

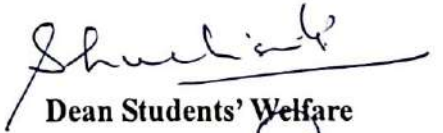
Keeping in view, it has been decided to extend the date of competition from 10 Feb. 2023 to 20 Feb. 2023. Results are to be sent to the O/o Dean Students' Welfare on the enclosed proforma latest by 21 Feb. 2023 so that the Round-II could be organized timely.

Dean Students' Welfare

08-2-23





KURUKSHETRA UNIVERSITY KURUKSHETRA

(Established by the State Legislature Act XII of 1956)
(**'A+' Grade, NAAC Accredited**)

Notice

Prof. Omvir Singh, Professor, Department of Geography and Dr. Archana Choudhary, Associate Professor, Department of Economics are appointed as Coordinator and Joint-Coordinator respectively with the permission of the Hon'ble Vice-Chancellor for organizing the ROSTRUM-2023 with immediate effect.

It is further informed that a meeting of the following members, to decide the topics for the 1st round of ROSTRUM-2023 competition, will be held on **28.12.2022 at 12:00 Noon** in the office of the undersigned:

1. Dean Students' Welfare
2. Coordinator, ROSTRUM-2023
3. Joint-Coordinator, ROSTRUM-2023

Members are requested to kindly make themselves available for the meeting as per the above schedule.

Dean Students' Welfare

Endst. No. DSW/2022/ 1609-1612

Dated: 27-12-2022

Copy of the above is forwarded to the following for information and necessary action:-

1. The Chairperson, Department of Geography, KUK
2. The Chairperson, Department of Economics, KUK
3. Prof. Omvir Singh, Professor, Department of Geography, KUK
4. Dr. Archana Choudhary, Associate Professor, Department of Economics, KUK

Dean Students' Welfare

received

DEAN STUDENTS' WELFARE
KURUKSHETRA UNIVERSITY KURUKSHETRA
(Established by the State Legislature Act XII of 1956)
("A" Grade, NAAC Accredited)

No.DSW/23/ 428-472
Dated:- 3/3/2023

To

All the **Chairpersons**,
University Teaching Departments,
Directors of the Institutes,
Principal, Institute of Integrated & Honors Studies
Principal, Institute of Teacher Training & Research
K. U. Kurukshetra,

Sub: - Rostrum-2022-23, Annual Public Speaking Competitions-Round-II

Dear Colleagues,

It is informed that Round-I of ROSTRUM-2022-23 has been a resounding success. **Round-II will be organized on 14, 15, 16, 17 & 18 Mar. 2023 as per attached schedule. Only winners of 1st Round will be eligible to participate in Rostrum-2022-23 Round-II on the prescribed date.** The list of the winners of Round-I has been supplied to the Coordinators of five groups of Departments/Institutes/Colleges. The following are enclosed:-

1. Schedule for Round-II
2. List of topics.
3. Rules and Guidelines

All the Chairpersons/Directors/Principals are requested to display the above on the notice board positively and get it noted personally from the winners of Round-I. It is important to mention here that the competition had been a success only because of the sustained interest and cooperation from all Departments/Institutes. It is, therefore, requested that cooperation and all possible assistance may please be extended for the successful completion of Round-II and thereafter.



Dean Students' Welfare
Kurukshetra University
Kurukshetra-136119.

Endst. No. DSW/23/ 473-476

Dated: 3/3/2023

Copy of the above is forwarded to all the above.

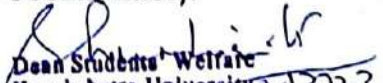
1. P.A. to the Vice-Chancellor for kind information of the Vice-Chancellor.
2. P.S. to the Registrar for kind information of the Registrar.
3. Prof. Omvir Singh (Over-all Coordinator).
4. Dr. Archana Chaudhry (Dept. of Economics)(Joint-Coordinator).

Dean Students' Welfare
Kurukshetra University
Kurukshetra-136119.

-10-23
ROSTRUM-2018 (Round-II)
Guidelines for Faculty Level Competitions

(14, 15, 16, 17 & 18 Mar.-2023)

1. The Presentation should be from 4-6 minutes. Paper reading will not be allowed.
2. Medium of Speech can either be Hindi or English only
3. Speakers must observe that anti-national remarks or the remarks which are not fact based and which hurt the sentiments of any community/religion/caste should not be made during the speech.
4. Decision of the judges will be final and no appeal shall be entertained regarding that at any stage.
5. A panel of two judges will be appointed by the Overall Coordinator/Joint Coordinator. The Coordinator of the respective Faculty will nominate two students (one to comper/coordinate the programme and one time keeper). Student comperer and time keeper will be paid an honorarium of Rs.500/- each.
6. A cash prize of Rs. 2000/-, Rs. 1500/- and Rs. 1000/- shall be admissible for Ist, IInd & IIIrd winners respectively of Round-II along with a certificate. Two special prizes of Rs. 750/- each will also be given. An honorarium of Rs. 700/- each will be given to two teacher judges and the teacher coordinator of the group.
7. All the coordinators are requested to submit the enclosed performa duly completed to the DSW office latest by **20 March- 2023** with a copy to Prof. Omvir Singh (Deptt. of Geography) or to Dr. Archna Chaudhry (Dept. of Economics).
8. DSW shall have the right to make any changes or relax any of the above guidelines or to take decision as and when the unforeseen situation demands.
9. **Note:** Any Clarifications may be sought from Prof. Omvir Singh (Deptt. of Geography) (94670-54590) and Dr. Archna Chaudhry (Dept. of Economics) (98965-37107).

Dean Students' Welfare
Kurukshetra-136119.

ROSTRUM-2022-23

Round-II

List of Topics

- 1 Agriculture Sector Subsidies: Pros and Cons
- 2 Opportunities for India in a Leadership Role of G-20 Nations in Present Scenario.
- 3 NEP-2020: Potential for Skilling the Youth of India
- 4 Water Management through Pani Panchayat Model
- 5 Connectivity of Bhagwad Gita with Youths: Present Status and Requirement.
- 6 Role of Students in Eradication of Drug Abuse
- 7 Atam Nirbhar Bharat through Research and Innovation
- 8 Khelo India: Its Role in Promotion of the Sports Culture in India

Dear Students' Welfare
Kurukshetra University,
Kurukshetra-136119.

[04-14-03-2023]

10

ROSTRUM-2022-23, (Depts./Inst) {No. of Students=26}

List of Participants of Faculty level, Stage-II, Dt.-(14.03.2023)

Name of the Department/ Faculty	Name of the Student	Class/Roll No.	Signatures
Deptt of Comm.	Garima	M Comm-F-127	
	Aarti	M Comm-F-05	
Library Science	Aaditya Pandey	M.Lib.I. Sc-8	
	Sandeep	B.Lib.I. Sc-6	
	Anil	M.Lib.I. Sc-6	
Dept. of Instrumentatio	Prahbha	B Tech III -40	
MCA	Ashu Devi	MCA-F-54	
	Anisha	MCA-I-8	
	Harsha Chawla	MCA-F-02	
Geophysics	Khushi	M.SC GP-II-07	
	Aditya Malik	M.SC GP-II-25	
	Rohit Chauhan	M.SC GP-II-05	
Physical Edu.	Vandana	MA Yoga-II-25	
	Jatinder	PG Yoga-F-25	
	Ankush Mor	MA Yoga-F-36	
W.S.R.C.	Khushboo	MA-IV-7	
	Rayman	PG Dip-7	
Uni. School of Mgt	Avni Mittal	MBA (P)-110	
	Muskan	MBA (P)-43	
	Aastha	MBA-(P)-01	
Inst. of Mgt Stud.	Komal	BBA (H)-II-6	
	Nisha	BBA (H)-II-1	
	Sneha	MBA-II Sem-23	
Tourism & Hotel Mgt.	Chinmey	BHMCT-27	
	Aman	MHMCT-09	
	Sahil	MHMCT-05	

ROSTRUM-2022-23, (Depts./Inst) {No. of Students=24}

List of Participants of Faculty level, Stage-II, Dt.-(16.03.2023)

Name of the Department/ Faculty	Name of the Student	Class/Roll No.	Signatures
Pol. Science	Vidhi	MA (P) -32	
	Vijeta	MA (F)Defence -23	
	Sunil	MA (F)Defence -12	
History	Komal Preet Kaur	MA (P)-21	
	Mahima Bhardwaj	MA (F)-13	
	Javed Khan	MA (F)-24	
Economics	Harshdeep Kaur	MA 4th Sem.-12	
	Shruti Arora	MA 2nd Sem.-38	
	Vaibhav Sharma	MABe 2nd Sem.-22	
Sociology	Aman	MA (F)-55	
	Sahil	MA (P)-34	
	Harish	MA (F)-23	
Social Work	Aditya Singh Maurya	MSW P-12	
	Neha	MSW F-10	
	Rajat	MSW P-49	
Philosophy	Uttam Kumar Ghosh	M.A Ist Sem-22	
	Ajay	C.C.M.Bhagwat Gita-01	
	Mona Makvandi	Dip in Yoga-8	
Music & Dance	Avinash	MPA-I-05	
	Himanshu	MPA-I-25	
	Jasveer	MPA-I-30	
Foreign Languages	Naveen	CC German-4	
	Rahul Sharma	CC German-40	
	Anu Rathi	CC Comm Skills-1	

ROSTRUM-2022-23, (Depts./Inst) {No. of Students=23}

List of Participants of Faculty level, Stage-II, Dt.-(17.03.2023)

Name of the Department/ Faculty	Name of the Student	Class/Roll No.	Signatures
Sanskrit	Anmol	M.A-P	
	Lavel	M.A-P	
Ancient Indian History	Alankriti	MA IInd Sem.-03	
	Gourav Kumar	PGDA-5	
	Vijeta	MA IInd Sem.-36	
Fine Arts (PG)	Anushka Jaw	BFA-IV-6	
	Devesh Taneja	BFA-VI-12	
	Sushila	BFA-II-47	
Inst. of Skt.&Ind. Std.	Harmeet Kaur	PGDKT-01	
Botany	Vandana	M Sc (P)-48	
	Ayushi	M Sc (F)-36	
	Deepanshi	M Sc (P)-60	
Education	Rahul	M Ed-III-02	
	Rajinder	B Ed-IISpl-16	
	Neha	B Ed-IVSpl-101	
Zoology	Rinku	M Sc (F)-36	
	Valuska Vats	M Sc (F)-4	
	Shagun	M Sc For. Sc.(F)-32	
Psychology	Ramandeep	MA (F)-25	
	Gursimar	MA (P)-24	
	Kiran Bishnoy	MA (P)-46	
Bio-Technology	Saloni	M Sc P-17	
	Sushmita	M Sc F-13	

ROSTRUM-2022-23, (Depts./Inst) {No. of Students=25}

List of Participants of Faculty level, Stage-II, Dt.-(18.03.2023)

Name of the Department/ Faculty	Name of the Student	Class/Roll No.	Signatures
Microbiology	Tejasvi	M Sc (F)-53	
	Aditi Saini	M Sc (P)-47	
	Manvi Chauhan	M Sc (P)-33	
Biochemistry	Shweta	M.Sc. P -8	
	Garima	M.Sc. P-45	
	Naina	M. Sc. F-18	
Inst. Env. Studies	Rhythm Sharma	M Sc (F)-12	
	Sahiba	M Sc (P)-27	
	Apurva	M Sc -F-23	
Dept. of Law	Bharti	L.L.B. IV-30	
	Priya	LLM-Ist-38	
	Karan	L.L.B. II-30	
Inst. of Law-	Ankit Bhardwaj	BA llb-4-116	
	Pratiksha	BA llb-6-16	
	Jayshree	BA llb-6-134	
	Upasana	BA llb-4-34	
Insitute of Teacher Training & Research	Shewta	B.Ed Ist-22148	
Mohd. Nazim Khan	Mohd. Nazim Khan	B.Ed II-21015	
	Aman Kumar	B.Ed Ist-22148	
Home Science	Khushboo	M.Sc. (FND)-29	
	Rashi	M.Sc.(FND) -38	
	Pragti	M.Sc.(FND) -30	
English	Vanya Gupta	MA (P)-74	
	Yashika Gera	MA (F)-92	
	Arindam	MA (F)-112	

DEAN STUDENTS' WELFARE
KURUKSHETRA UNIVERSITY KURUKSHETRA
(Established by the State Legislature Act XII of 1956)
(**'A'+ Grade, NAAC Accredited**)

No. DSW/23/_____

Dated: - _____

Notice

The Dean Students Welfare office is organizing Faculty Round of Rostrum-2022-23, (Annual Public Speaking Competitions) w.e.f. 14 Mar. to 18 Mar. 2023 at 01.00. PM onwards in the Faculty Lounge. The following Officers/Incharges are requested to make arrangements/provisions as specified:-

1. XEN : To make light, sound and power back up arrangement w.e.f. 14 Mar. to 18 Mar. 2023 at 01.00 pm onwards 06/3/2023
2. Officer Incharge (Sanitation) : For necessary action regarding cleaning of the venue. 06/3/23
3. Director Public Relations : For information and for further media coverage of the event. 31/3/23
4. Chief Security Officer : For information and necessary action 3/3/23
5. DYCA : For booking the Faculty Lounge w.e.f. 14 Mar. to 18 Mar. 2023 at their own level, in the light of the standing orders of the Vice-Chancellor. 06-03-2023

Dean Students' Welfare
Dean Students' Welfare
Kurukshetra University,
Kurukshetra-136119.

Endst.No. DSW/23/ 423-427

Dated: 3/3/2023

Copy of the above is forwarded to all the above.

Dean Students' Welfare
Dean Students' Welfare
Kurukshetra University,
Kurukshetra-136119.

DEAN STUDENTS' WELFARE
KURUKSHETRA UNIVERSITY KURUKSHETRA
(Established by the State Legislature Act XII of 1956)
("A+" Grade, NAAC Accredited)

To

The Chairpersons/Directors,
University Teaching Departments/Institute,
Kurukshetra University Kurukshetra

- | | |
|---------------------------------|-----------------------------|
| 1. Dept. of Commerce | 11. Dept. of Social Work |
| 2. Dept. of Economics | 12. Deptt. of Bio-Chemistry |
| 3. Dept. of Statistics & O.R. | 13. Deptt. of Micro-Biology |
| 4. Dept. of Chemistry | 14. Dept. of Botony |
| 5. Inst. of Law | 15. Dept. of History |
| 6. Dept. of Computer Science | 16. Dept. of Zoology |
| 7. Dept. of Mathematics | 17. Dept. of Education |
| 8. Dept. of Foreign Lang. | 18. Dept. of Bio-Technology |
| 9. Dept. of Geography | 19. Dept of English |
| 10. Dept. of Physical Education | |

Sub: - One Day Workshop for the winners of ROSTRUM-2022-23, Round-II

Dear Colleagues,

The first two rounds of Rostrum 2022-23, Annual Public Speaking Competition, have now been successfully completed. Now, it is proposed to organize one day workshop for the winners of the Round-II on **31th Mar. 2023 at 10:00 am** onwards in the Senate Hall (Auditorium Building). **The enclosed list includes students of your Department/Institute who had won position in the Round-II of competition.**

May I request you to kindly **direct your office to contact the students and instruct them to report in the Senate Hall at 09:45 am on 31th Mar. 2023.** Experts would interact with the winners of Round-II in order to sharpen their public speaking skills and it is compulsory for the winner students to attend the workshop.

Sincerely Yours,

Dean Students' Welfare

Endst. No. DSW/23/ 674-697

Dated: 20/3/2023

Copy of the above is forwarded to all the above.

1. P.A .to Vice-Chancellor for kind information of the Vice-Chancellor.
2. A.R O/o Registrar for kind information of the Registrar.
3. Prof. Omvir Singh (Over-all Coordinator).
4. Dr. Archana Chaudhry (Joint-Coordinator).

Dean Students Welfare

DEAN STUDENTS' WELFARE
KURUKSHETRA UNIVERSITY KURUKSHETRA
(Established by the State Legislature Act XII of 1956)
("A+" Grade, NAAC Accredited)

To

The Chairpersons/Directors,
University Teaching Departments/Institute,
Kurukshetra University Kurukshetra

- | | |
|---------------------------------|-----------------------------|
| 1. Dept. of Commerce | 11. Dept. of Social Work |
| 2. Dept. of Economics | 12. Deptt. of Bio-Chemistry |
| 3. Dept. of Statistics & O.R. | 13. Deptt. of Micro-Biology |
| 4. Dept. of Chemistry - | 14. Dept. of Botony |
| 5. Inst. of Law | 15. Dept. of History |
| 6. Dept. of Computer Science | 16. Dept. of Zoology |
| 7. Dept. of Mathematics | 17. Dept. of Education |
| 8. Dept. of Foreign Lang. | 18. Dept. of Bio-Technology |
| 9. Dept. of Geography - | 19. Dept of English |
| 10. Dept. of Physical Education | |

Sub: - One Day Workshop for the winners of ROSTRUM-2022-23, Round-II

Dear Colleagues,

The first two rounds of Rostrum 2022-23, Annual Public Speaking Competition, have now been successfully completed. Now, it is proposed to organize one day workshop for the winners of the Round-II on **31th Mar. 2023** at **10:00 am** onwards in the Senate Hall (Auditorium Building). **The enclosed list includes students of your Department/Institute who had won position in the Round-II of competition.**

May I request you to kindly **direct your office to contact the students and instruct them to report in the Senate Hall at 09:45 am on 31th Mar. 2023.** Experts would interact with the winners of Round-II in order to sharpen their public speaking skills and it is compulsory for the winner students to attend the workshop.

Sincerely Yours,

Shuchi
Dean Students' Welfare

Endst. No. DSW/23/ 674-697

Dated: 20/3/2023

Copy of the above is forwarded to all the above.

1. P.A .to Vice-Chancellor for kind information of the Vice-Chancellor.
2. A.R O/o Registrar for kind information of the Registrar.
3. Prof. Omvir Singh (Over-all Coordinator).
4. Dr. Archana Chaudhry (Joint-Coordinator).

Shuchi
Dean Students Welfare

-24-

ROSTRUM-2022-23

List of winner students of Round-II who participate One day Workshop

Date/Venue	Name of the student	Class/Roll No.	Signatures		
Senate Hall@	Vandana	MA Yoga Ist/25			
31.03.2023 @	Deepanshi	M Sc Botony/60			
3	Ayushi	M Sc Botony/36			
4	Arti	M Comm.(F)-5			
5	Harsha Chawla	M Sc Computer Sc.			
6	Advitya	M Sc Geography/02			
7	Akshat	M Sc Chem/104			
8	Richa Tyagi	M Sc Math./95			
9	Shruti	M SC Chem/47			
10	Sanyam	M SC Stat./38			
11	Rahul Sharma	CC German-40			
12	Naveen	CC German-04			
13	Harshdeep Kaur	MA Eco-12			
14	Aditya Singh	MSW/12			
15	Mahima Bhardwaj	MA History/13			
16	Valuska Vats	M Sc F Zoology/04			
17	Neha	B Ed Spl.101			
18	Rinku	M Sc F Zoology/36			
19	Rahul	M Ed F-02			
20	Saloni	M Sc Bio-Tech/17			
21	Jayshree	BA LLb-6th-134			
22	Ankit	BA LLb-4-116			
23	Vanya Gupta	MA (P) Eng-74			

ROSTRUM-2022-23

List of winner students of Round-II who participate One day Workshop

Date/Venue	Name of the student	Class/Roll No.	Signatures	Mobile No.
Senate Hall@	Vandana	MA Yoga Ist/25	2732	90341-05746
31.03.2023	Deepanshi ✓	M Sc Botony/60 ✓		70111-89514
3	Ayushi ✓	M Sc Botony/36		98969-18364
4	Arti ✓	M Comm.(F)-5		98131-74732
5	Harsha Chawla ✓	M Sc Computer Sc.		74045-91669
6	Advitya ✓	M Sc Geography/02		98178-62081
7	Akshat ✓	M Sc Chem/104		94678-26026
8	Richa Tyagi	M Sc Math./95	2575	93065-40586
9	Shruti ✓	M SC Chem/47		92555-24767
10	Sanyam	M SC Stat./38	2510	
11	Rahul Sharma	CC German-40	2595	81688-20684
12	Naveen	CC German-04	81686-18514	86838-64931
13	Harshdeep Kaur	MA Eco-12	2564	8396813635
14	Aditya Singh	MSW/12	2557	9582578336
15	Mahima Bhardwaj	MA History/13	2559	79072-70455
16	Valuska Vats	M Sc F Zoology/04	2498	93184-07757
17	Neha Gnutam	B Ed Spl.101	2507	9813906860 / 857195350
18	Rinku	M Sc F Zoology/36		97123-00157
19	Rahul ✓	M Ed F-02		86838-64931
20	Saloni ✓	M Sc Bio-Tech/17		90537-12557
21	Jayshree	BA LLb-6th-134	2404	90343-10173
22	Ankit	BA LLb-4-116		94169-64031
23	Vanya Gupta	MA (P) Eng-74	2567	94676-48860

-42-

DEAN STUDENTS' WELFARE
KURUKSHETRA UNIVERSITY KURUKSHETRA
(Established by the State Legislature Act XII of 1956)
("A+" Grade, NAAC Accredited)

To

The Chairpersons/Directors,
University Teaching Departments/Institute,
Kurukshetra University Kurukshetra

- | | |
|---------------------------------|-----------------------------|
| 1. Dept. of Commerce | 11. Dept. of Social Work |
| 2. Dept. of Economics | 12. Deptt. of Bio-Chemistry |
| 3. Dept. of Statistics & O.R. | 13. Deptt. of Micro-Biology |
| 4. Dept. of Chemistry | 14. Dept. of Botony |
| 5. Inst. of Law | 15. Dept. of History |
| 6. Dept. of Computer Science | 16. Dept. of Zoology |
| 7. Dept. of Mathematics | 17. Dept. of Education |
| 8. Dept. of Foreign Lang. | 18. Dept. of Bio-Technology |
| 9. Dept. of Geography | 19. Dept of English |
| 10. Dept. of Physical Education | |

Sub: - ROSTRUM-2022-23, Round-III (Final Stage) Symposium.

Dear Colleagues,

The first two rounds of Rostrum 2022-23, Annual Public Speaking Competition, have now been successfully completed. It is proposed to organize Final round of Round-III on **11th April, 2023 at 10:30 am** onwards in the Senate Hall (Auditorium Building). **The enclosed list includes students of your Department/Institute who had won position in the Round-II of competition.**

May I request you to kindly **direct your office to contact the students and instruct them to report in the Senate Hall at 10:15 am on 11th April, 2023.** I am also enclosing guidelines for the competition and a list of topics on which students are expected to speak. May I further request to please circulate these guidelines and topics to the concerned students. Requisite number of sets of the guidelines/topics is also enclosed.

Sincerely Yours,

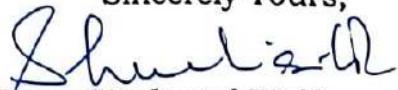
Dean Students' Welfare

Endst. No. DSW/23/ 825-848

Dated: 05-04-23

Copy of the above is forwarded to all the above.

1. P.A .to Vice-Chancellor for kind information of the Vice-Chancellor.
2. A.R O/o Registrar for kind information of the Registrar.
3. Prof. Omvir Singh (Over-all Coordinator).
4. Dr. Archana Chaudhry (Joint-Coordinator).

Dean Students Welfare

-43-

ROSTRUM-2022-23 (Stage-III) SYMPOSIUM
Guidelines

1. The Final round of Rostrum will be in the form of Symposium.
2. The presentation should be 3 to 5 minutes. Paper reading will not be allowed. After completion of the presentation open house discussion will be held in which atleast one question will be asked from judges' panel and two questions may be asked by the audience.
3. Medium of speech can be either English or Hindi.
4. Speakers must observe that no anti-national remarks or the remarks which are not fact based and which hurts the sentiments of any community/religion/caste be made during the speech.
5. The topics of the final round will be displayed on the notice board of DSW, on the students notices at KUK website and will be intimated to the respective Chairperson/Director for further display among concerned students of the Deptt./Inst. through email.
6. There will be three judges to be appointed by the Overall Coordinator/Joint Coordinator. The Coordinator will also nominate two students (one to comperere/coordinate the programme and other as time keeper). It will mainly be a student activity comperered and coordinated by the students. Teachers will only help and guide the students. Coordinator and Teacher Judges will be paid an honorarium of Rs. 1000/- each. An honorarium of Rs. 700/- (each) will be given to the student coordinator/compererer and time keeper.
7. A cash prize of Rs. 5100/- ,Rs. 4100/-, and Rs. 3100/- 'along with a certificates' will be given to the students winning First , Second and Third positions respectively. Three special prizes of Rs. 1000/- each will also be given to the participants.
8. The event coordinator will submit the enclosed proforma duly completed to the DSW office after the completion of the competition.
9. Decision of the judges shall be final and no appeal shall be entertained regarding that.
10. DSW shall have the right to make any change or relax any of the above guidelines or to take decision as the unseen situation demands.

A special function will be organized for the prize distribution probably in the last week of April 2023.

Note: Any clarifications may be sought from Prof. Omvir Singh, Dept. of Geography (94670-54590) & Dr. Archana Chaudhry, Deptt. of Economics (98965-37107)

Dean Students' Welfare

-44-

ROSTRUM-2022-23

Round-III

List of Topics

- 1 Startup Ecosystem in India
- 2 G-20: Its Role in Attainment of Sustainable Development
- 3 NEP-2020 in the Age of Media
- 4 Water is Climate and Climate is Water
- 5 Bhagwad Gita : Permanent Dimension of Human Consciousness and Values
- 6 Social Media : Pros and Cons
- 7 Amrit Kaal: Creating New Vision
- 8 Is Politics Hampering the Joys of Playing Sports?
- 9 Green Hydrogen for a Sustainable and 'Aatamnirbhar' India

Dean Students' Welfare

ROSTRUM-2022-23

List of Participants of Round-III (Venue Senate Hall) Dt. 11.04.2023

Date/Venue	Name of the student	Class/Roll No.	Signatures		
Senate Hall 31.03.2023	Vandana	MA Yoga Ist/25			
	Deepanshi	M Sc Botony/60			
	Ayushi	M Sc Botony/36			
	Arti	M Comm.(F)-5			
	Harsha Chawla	M Sc Computer Sc.			
	Advitya	M Sc Geography/02			
	Akshat	M Sc Chem/104			
	Richa Tyagi	M Sc Math./95			
	Shruti	M SC Chem/47			
	Sanyam	M SC Stat./38			
	Rahul Sharma	CC German-40			
	Naveen	CC German-04			
	Harshdeep Kaur	MA Eco-12			
	Aditya Singh	MSW/12			
	Mahima Bhardwaj	MA History/13			
	Valuska Vats	M Sc F Zoology/04			
Neha	B Ed Spl.101				
Rinku	M Sc F Zoology/36				
Rahul	M Ed F-02				
Saloni	M Sc Bio-Tech/17				
Jayshree	BA LLb-6th-134				
Ankit	BA LLb-4-116				
Vanya Gupta	MA (P) Eng-74				

Thanking You,



-46-

Date/Venue	Name of the student	Class/Roll No.	Signatures		
	Manvi Chauhan	M Sc. Microbio-33			
	Shweta	M Sc Biochem-8			
	Upasana	BA LLb/34			

Thanking You,

Encls: As above.

Shuchand
Dean Students' Welfare





ROSTRUM – 2022-23
Annual Public Speaking Competition
KURUKSHETRA UNIVERSITY, KURUKSHETRA
(Established by the State Legislature Act XII of 1956)
(‘A+’ Grade, NAAC Accredited)

CERTIFICATE OF MERIT

*This certificate is awarded to _____
S/D/o _____ a student of Class _____
Department/Institute _____ Session 2022-2023 in recognition of having
won _____ position in the Round _____ of the Rostrum competition.*

(Prof. Shuchismita)
DEAN STUDENTS' WELFARE

(Prof. Omvir Singh)
OVERALL CO-ORDINATOR

(Dr. Archana Chaudhary)
JOINT CO-ORDINATOR

DEAN STUDENTS' WELFARE
KURUKSHETRA UNIVERSITY KURUKSHETRA

(Established by the State Legislature Act XII of 1956)
(‘A+’ Grade, NAAC Accredited)

URGENT

No. DSW/23/ 918-968

Dated: 21-04-2023

To

All the **Chairpersons**,
University Teaching Departments,
All **Directors** of Institutes,
Principal, Institute of Integrated & Honors studies,
Institute of Teacher Training & Research

Sub: Annual Prize Distribution Function of ROSTRUM-2022-23.

The Annual prize distribution function of Rostrum-2022-23 (Annual Public Speaking Competitions) organized by the office of DSW will be held on **26th April 2023 at 02.30 pm in the Senate Hall (Auditorium building).**

Hon'ble Vice-Chancellor, Kurukshetra University has kindly consented to be the Chief Guest and to confer the prizes along with certificates to the winners.

Prize winning students of your Department/Institute, whose list is attached, may please be directed to be present in the prize distribution function to receive the certificates.

May I, therefore, request your office to inform personally the prize winning students of your Department/Institute, who have got positions at different rounds of Rostrum-2022-23 to be present before **2:30 pm on 26th April 2023** in the Senate Hall (Auditorium building) and mark their presence to receive the certificates.

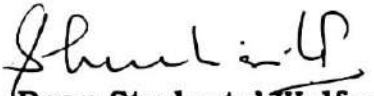
Dean Students' Welfare

Note: All winner students alongwith comperer and time keeper are required to check and verify their bank details personally in the list displayed in the Senate Hall. Thereafter no request will be entertained in any case. After their verification, the amount will be transfered directly into their account.

Endst. No. DSW/23/_____

Dated: _____

Copy to:-

1. All the above for necessary action.
2. OSD to Vice-Chancellor for kind information of the Vice- Chancellor.
3. PS to Registrar for kind information of the Registrar.
4. Prof. Omvir Singh, (Overall Co-ordinator) ROSTRUM-2022-23.
5. Dr. Archana Chaudhry, (Joint Co-ordinator) ROSTRUM-2022-23.

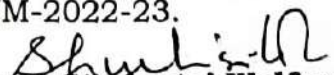
Dean Students' Welfare

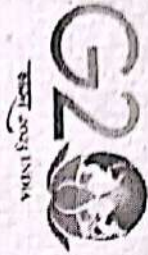

75
आजादी का
अमृत महोत्सव

DEAN STUDENTS' WELFARE KURUKSHETRA UNIVERSITY, KURUKSHETRA

(ESTABLISHED BY THE STATE LEGISLATURE ACT XII OF 1956)

(‘A+’ GRADE, NAAC ACCREDITED)

Welcomes on the Occasion of

PRIZE DISTRIBUTION FUNCTION (ROSTRUM 2022-23)

CHIEF GUEST : **PROF. SOMNATH SACHDEVA**
HON'BLE VICE-CHANCELLOR

APRIL 26, 2023 | VENUE: SENATE HALL

DR. ARCHNA CHAUDHRY
JOINT COORDINATOR, ROSTRUM

PROF. OMVIR SINGH
COORDINATOR, ROSTRUM

PROF. SHUCHISMITA
DEAN STUDENTS' WELFARE



**DEAN STUDENTS' WELFARE
KURUKSHETRA UNIVERSITY KURUKSHETRA**

(Established by the State Legislature Act XII of 1956)

('A+' Grade, NAAC Accredited)

No. DSW/23/ 975-1024
Dated:- April 24, 2023

To

**The Chairperson/Director,
University Teaching Department/Institute
Kurukshetra University, Kurukshetra**

Sub: Invitation of "ROSTRUM 2022-23" (Annual Public Speaking Competition)- Prize Distribution Function.

Dear Sir/Madam,

The DSW Office has been organizing the "ROSTRUM" (Annual Public Speaking Competition) for the students of UTD/Institutes/Colleges for the last fifteen years. These competitions have proved a great success this year. About 2664 students participated in the deliberations and 574 students actually participated as speakers, out of which 157 students have got positions.

Now, the Prize Distribution function of "ROSTRUM 2022-23" will be held on 26th April 2023 at 03:00 pm in the Senate Hall. The Hon'ble Vice-Chancellor Prof. Som Nath Sachdeva will be the Chief Guest on the occasion.

May I request you to kindly grace the event with your presence and spare some valuable time for the occasion.

With regards

Shuchismita 24/4/23
Dean Students' Welfare

पुरस्कार

केयू ने रोस्ट्रम प्रतियोगिता के विजेताओं को सम्मान से नयाजा

संवाद में संवेदनाओं और भाव का होना जरूरी

संवाद न्यूज एजेंसी

कुरुक्षेत्र। कुलपति प्रोफेसर सोमनाथ सचदेवा ने कहा कि केयू विद्यार्थियों के सर्वांगीण विकास के लिए प्रतिबद्ध है। भाषण कला को बढ़ावा देने के लिए रोस्ट्रम जैसी प्रतियोगिताओं का आयोजन भविष्य में और भी बड़े स्तर पर करने की योजना है। कुलपति बुधवार को रोस्ट्रम के विजेता विद्यार्थियों को पुरस्कार वितरित करते हुए विचार व्यक्त कर रहे थे।

कुलपति ने कहा कि राष्ट्रीय शिक्षा नीति 2020 में भी मुख्य रूप से युवाओं के सर्वांगीण विकास, मूल्य परक शिक्षा, स्किल डेवलपमेंट, रोजगारपरक शिक्षा, आचरण में नैतिक गुणों को

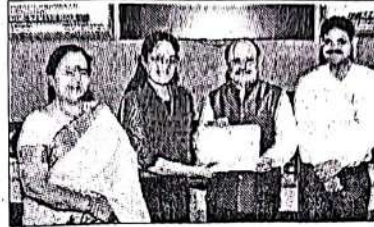

विजेता छात्रा को सम्मानित करते कुलपति।

आत्मसात कर उनके सशक्त चरित्र-निर्माण के लिए एक सतत प्रयास किया गया है। उन्होंने कहा कि संवाद कला जितनी बारीकी से सीखनी पड़ती है, उसी बारीकी से किसी भी विषय पर विस्तारपूर्वक जानकारी का अध्ययन करना पड़ता

है। भाषा की जानकारी के साथ-साथ अपने संवाद में संवेदनाएं व भाव भी व्यक्त करना एक अच्छे वक्ता की पहचान है।

अधिष्ठाता छात्र कल्याण प्रो. शुचिस्मिता ने कहा कि रोस्ट्रम एक भाषण प्रतियोगिता है, जो तीन स्तर पर आयोजित की जाती है, जिसमें केयू के सभी विभागों के विद्यार्थी भाग लेते हैं। इस वर्ष अलग-अलग स्तर पर 256 विजेताओं में दो लाख 60 हजार 900 रुपये की धनराशि वितरित की गई। रोस्ट्रम के संयोजक प्रो. ओमवीर सिंह ने कार्यक्रम की रिपोर्ट में बताया कि पहले राउंड में 44 विभागों के 2471 विद्यार्थियों ने कार्यक्रम में भाग लिया और 451 विद्यार्थियों ने भाषण प्रतियोगिता में भाग लिया।

संवाद करते समय भाव व्यक्त करना एक अच्छे वक्ता की पहचान : प्रोफेसर सोमनाथ सचदेवा

जागरण संवाददाता, कुरुक्षेत्र : बुधवार को रोस्ट्रम के विजेता विद्यार्थियों को पुरस्कार वितरण समारोह आयोजित किया गया, जिसमें मुख्यातिथि कुरुक्षेत्र विश्वविद्यालय के कुलपति प्रोफेसर सोमनाथ सचदेवा रहे। इस मौके पर फाइनल राउंड के विजेताओं में से दो विजेता रिचा त्यागी ने अमृतकाल और जयश्री ने गीता के विषय पर अपने भाषण की प्रस्तुति दी। कुलपति प्रोफेसर सोमनाथ सचदेवा ने कहा कि कुरुक्षेत्र विश्वविद्यालय विद्यार्थियों के सर्वांगीण विकास के लिए प्रतिबद्ध है और भाषण कला को बढ़ावा देने के लिए रोस्ट्रम जैसी प्रतियोगिताओं का आयोजन भविष्य में और भी बड़े स्तर पर करने की योजना है। उन्होंने कहा कि संवाद-कला जितनी बारीकी से सीखनी पड़ती है, उसी बारीकी से किसी भी विषय पर विस्तारपूर्वक जानकारी का अध्ययन करना पड़ता है। भाषा की जानकारी के साथ-साथ अपने संवाद में संवेदनाएं व भाव भी व्यक्त करना एक अच्छे वक्ता



विजेता छात्रा को सम्मानित करते हुए कुलपति प्रोफेसर सोमनाथ सचदेवा। • सौजन्य : प्रवक्ता की पहचान है। उन्होंने भाषण कला का विद्यार्थियों के जीवन में महत्व विद्यार्थियों के साथ साक्षात् करते हुए उनके उज्ज्वल भविष्य की कामना की।

विशिष्ट अतिथि कुलसचिव प्रोफेसर संजीव शर्मा ने भी विद्यार्थियों का उत्साहवर्धन करते हुए उन्हें बधाई दी। इसके पूर्व अधिष्ठाता छात्र कल्याण प्रो. शुचिस्मिता ने अतिथियों का स्वागत किया। प्रोफेसर शुचिस्मिता ने कहा कि रोस्ट्रम एक भाषण प्रतियोगिता है जो तीन स्तर

पर आयोजित की जाती है और कुरुक्षेत्र विश्वविद्यालय के सभी विभागों के विद्यार्थी इसमें भाग लेते हैं। इस वर्ष अलग-अलग स्तर पर 256 विजेताओं में दो लाख 60 हजार 900 रुपये की धनराशि वितरित की गई। इस प्रतियोगिता के आयोजन में भी विद्यार्थियों की अहम भूमिका रहती है। रोस्ट्रम 2022 के संयोजक प्रो. ओमवीर सिंह ने कार्यक्रम की रिपोर्ट में बताया कि पहले राउंड में 44 विभागों के 2471 विद्यार्थियों ने कार्यक्रम में भाग लिया।

केयू ने रोस्ट्रम प्रतियोगिता के विजेताओं को सम्मान से नवाजा

संवाद में संवेदनाओं और भाव का होना जरूरी



विजेता छात्रा को सम्मानित करते कुलपति।

कुरुक्षेत्र। कुलपति प्रोफेसर सोमनाथ सचदेवा ने कहा कि केयू विद्यार्थियों के सर्वांगीण विकास के लिए प्रतिबद्ध है। भाषण कला को बढ़ावा देने के लिए रोस्ट्रम जैसी प्रतियोगिताओं का आयोजन भविष्य में और भी बड़े स्तर पर करने की योजना है। कुलपति बुधवार को रोस्ट्रम के विजेता विद्यार्थियों को पुरस्कार वितरित करते हुए विचार व्यक्त कर रहे थे।

कुलपति ने कहा कि राष्ट्रीय शिक्षा नीति 2020 में भी मुख्य रूप से युवाओं के सर्वांगीण विकास, मूल्य परक शिक्षा, स्किल डेवलपमेंट, रोजगारपरक शिक्षा, आचरण में नैतिक गुणों को

आत्मसात कर उनके सशक्त चरित्र-निर्माण के लिए एक सतत प्रयास किया गया है। उन्होंने कहा कि संवाद कला जितनी बारीकी से सीखनी पड़ती है, उसी बारीकी से किसी भी विषय पर विस्तारपूर्वक जानकारी का अध्ययन करना पड़ता

है। भाषण की जानकारी के साथ-साथ अपने संवाद में संवेदनाएं व भाव भी व्यक्त करना एक अच्छे वक्ता की पहचान है।

अधिष्ठाता छात्र कल्याण प्रो. शुचिस्मिता ने कहा कि रोस्ट्रम एक भाषण प्रतियोगिता है जो तीन स्तर पर आयोजित की जाती है जिसमें केयू के सभी विभागों के विद्यार्थी भाग लेते हैं। इस वर्ष अलग-अलग स्तर पर 256 विजेताओं में दो लाख 60 हजार 900 रुपये की धनराशि वितरित की गई। रोस्ट्रम के संयोजक प्रो. ओमवीर सिंह ने कार्यक्रम की रिपोर्ट में बताया कि पहले राउंड में 44 विभागों के 2471 विद्यार्थियों ने कार्यक्रम में भाग लिया और 451 विद्यार्थियों ने भाषण प्रतियोगिता में भाग लिया।

संवाद करते समय भाव व्यक्त करना एक अच्छे वक्ता की पहचान: प्रोफेसर सोमनाथ सचदेवा

जागरण संवाददाता, कुरुक्षेत्र: बुधवार को रोस्ट्रम के विजेता विद्यार्थियों को पुरस्कार वितरण समारोह आयोजित किया गया, जिसमें मुख्यातिथि कुरुक्षेत्र विश्वविद्यालय के कुलपति प्रोफेसर सोमनाथ सचदेवा रहे। इस मौके पर फाइनल राउंड के विजेताओं में से दो विजेता रिचा त्यागी ने अमृतकाल और जयश्री ने गीता के विषय पर अपने भाषण की प्रस्तुति दी। कुवि कुलपति प्रोफेसर सोमनाथ सचदेवा के कहा कि कुरुक्षेत्र विश्वविद्यालय विद्यार्थियों के सर्वांगीण विकास के लिए प्रतिबद्ध है और भाषण कला को बढ़ावा देने के लिए रोस्ट्रम जैसी प्रतियोगिताओं का आयोजन भविष्य में और भी बड़े स्तर पर करने की योजना है। उन्होंने कहा कि संवाद कला जितनी बारीकी से सीखनी पड़ती है, उसी बारीकी से किसी भी विषय पर विस्तारपूर्वक जानकारी का अध्ययन करना पड़ता है। भाषा की जानकारी के साथ-साथ अपने संवाद में संवेदनाएं व भाव भी व्यक्त करना एक अच्छे वक्ता

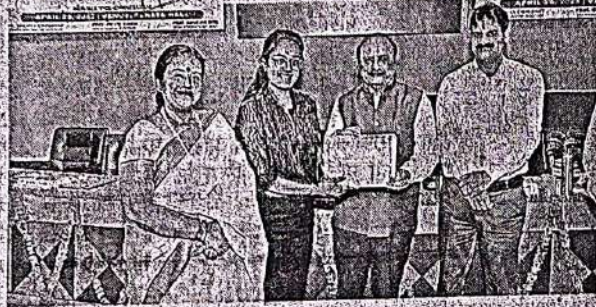

विजेता छात्रा को सम्मानित करते हुए कुलपति प्रोफेसर सोमनाथ सचदेवा।

की पहचान है। उन्होंने भाषण कला का विद्यार्थियों के जीवन में महत्व विद्यार्थियों के साथ साझा करते हुए उनके उज्वल भविष्य की कामना की।

विशिष्ट अतिथि कुलसचिव प्रोफेसर संजीव शर्मा ने भी विद्यार्थियों का उत्साहवर्धन करते हुए उन्हें बधाई दी। इसके पूर्व अधिष्ठाता छात्र कल्याण प्रो. शुचिस्मिता ने अतिथियों का स्वागत किया। प्रोफेसर शुचिस्मिता ने कहा कि रोस्ट्रम एक भाषण प्रतियोगिता है जो तीन स्तर

पर आयोजित की जाती है और कुरुक्षेत्र विश्वविद्यालय के सभी विभागों के विद्यार्थी इसमें भाग लेते हैं। इस वर्ष अलग-अलग स्तर पर 256 विजेताओं में दो लाख 60 हजार 900 रुपये की धनराशि वितरित की गई। इस प्रतियोगिता के आयोजन में भी विद्यार्थियों की अहम भूमिका रहती है। रोस्ट्रम 2022 के संयोजक प्रो. ओमवीर सिंह ने कार्यक्रम की रिपोर्ट में बताया कि पहले राउंड में 44 विभागों के 2471 विद्यार्थियों ने कार्यक्रम में भाग लिया।

'ROSTRUM' concludes



KURUKSHETRA, APR 27

The famous ROSTRUM public speaking competition of Kurukshetra University concluded with prize distribution function on Wednesday. Vice Chancellor KU Prof. Som Nath Sachdeva was the chief guest and gave away the prizes to the winners. The competition is held annually at three levels: department, faculty, and university. In all, there were 558 students who spoke on a variety of topics. Total prize money worth Rs. 2,60,000 was awarded to 256 students who won at different levels. The first prize at the university level was won by Ms Richa Tyagi of the Dept. of Mathematics, second prize was won by Ms Shweta from the Dept of Biochemistry and third went to Valuska Vats from Dept of Zoology. Congratulating the winners Prof Som Nath said, "This Public speaking competitions is highly motivating for young students. Importantly, it is non-adversarial format which hones research, organisation, and presentation skills of students. It promotes confidence, critical thinking and broadens participants' horizons and opportunities." "We have created more scope for the overall development of students in our Undergraduate programmes which have been designed and implemented as per NEP-2020. Along with public speaking and other skills, students learn about Indian Knowledge system, Modern Indian Languages, community engagement and critical



भाव व्यक्त करना एक अच्छे वक्ता की पहचान: प्रो. सोमनाथ केयू में रोस्ट्रम प्रतियोगिता- वार्षिक पुरस्कार वितरण समारोह आयोजित



कुरुक्षेत्र (डी.आर.भटनागर) : कुरुक्षेत्र विश्वविद्यालय विद्यार्थियों के सर्वांगीण विकास के लिए प्रतिबद्ध है तथा भाषण कला को बढ़ावा देने के लिए रोस्ट्रम जैसी प्रतियोगिताओं का आयोजन भविष्य में और भी बड़े स्तर पर करने की योजना है। यह विचार कुरुक्षेत्र विश्वविद्यालय के कुलपति प्रो. सोमनाथ सचदेवा ने बुधवार को रोस्ट्रम के विजेता विद्यार्थियों को पुरस्कार वितरित करते हुए अभिव्यक्त किए। इससे पहले सरस्वती पूजन, दीप प्रज्वलन एवं कुलगीत के साथ कार्यक्रम का शुभारंभ किया गया। कुलपति ने कहा कि राष्ट्रीय शिक्षा नीति 2020 में भी मुख्य रूप से युवाओं के सर्वांगीण विकास, मूल्य परक शिक्षा, स्किल डेवलपमेंट, रोजगार परक शिक्षा, आचरण में नैतिक गुणों को आत्मसात कर उनके सशक्त चरित्र-निर्माण के लिए एक सतत प्रयास है। इसी के मद्देनजर कुरुक्षेत्र विश्वविद्यालय अपने विद्यार्थियों के हितों के लिए संकल्पबद्ध है। कुलपति प्रो. सोमनाथ सचदेवा ने कहा कि संवाद कला जितनी बारीकी से सीखनी पड़ती है उतनी बारीकी से किसी भी विषय पर विस्तारपूर्वक जानकारी का अध्ययन करना पड़ता है। भाषा की जानकारी के साथ-साथ अपने संवाद में संवेदनाएं व भाव भी व्यक्त करना एक अच्छे वक्ता की पहचान है। उन्होंने भाषण कला का विद्यार्थियों के जीवन में महत्व विद्यार्थियों के साथ साझा करते हुए उनके उज्ज्वल भविष्य की कामना की। कार्यक्रम के विशिष्ट

अतिथि कुलसचिव प्रो. संजीव शर्मा ने भी विद्यार्थियों का स्वागत करते हुए उन्हें बधाई दी। इसके पूर्व अधिष्ठाता छात्र कल्याण प्रो. शुचिस्मिता ने अतिथियों का स्वागत किया तथा स्वागत दिव्य के रूप में मंत्र मंत्र किए। प्रो. शुचिस्मिता ने कहा कि रोस्ट्रम एक भाषण प्रतियोगिता है जो तीन स्तर पर आयोजित की जाती है तथा कुरुक्षेत्र विश्वविद्यालय के सभी विभागों के विद्यार्थी इनमें भाग लेते हैं। इस वर्ष अलग-अलग स्तर पर 256 विजेताओं में 2 लाख 60 हजार 900 रुपये की धनराशि वितरित की गई। इस प्रतियोगिता के आयोजन में भी विद्यार्थियों की अहम भूमिका रहती है। रोस्ट्रम 2022 के संयोजक प्रो. ब्रजेश साहनी ने कार्यक्रम की रिपोर्ट में बताया कि पहले राउंड में 44 विभागों के 2471 विद्यार्थियों ने कार्यक्रम में भाग लिया और 451 विद्यार्थियों ने भाषण प्रतियोगिता में भाग लिया जिनमें से 123 को पुरस्कार मिला। दूसरे राउंड में 81 वक्ता थे जिनमें से 26 विद्यार्थी विजेता हुए। इस तरह ओवरऑल तीनों राउंड में 2811 विद्यार्थियों ने प्रतियोगिता को और 558 ने भाषण दिया। सह-संयोजिका डॉ. अर्चना चौधरी ने धन्यवाद प्रस्ताव दिया। इस मौके पर फाइनेल राउंड के विजेताओं में से दो विजेताओं रिवा त्पानी ने अनूतकाल तथा जयश्री ने गीता के विषय पर अपने भाषण को प्रस्तुत किया। इत अवसर पर मंच संचालन विधि विभाग की अनुराधा ने किया। इस मौके पर कुलपति प्रो. संजीव शर्मा, छात्र कल्याण अधिष्ठाता प्रो. शुचिस्मिता, प्रो. एतकेश्वर प्रो. ब्रजेश साहनी, प्रो. ओमवीर सिंह, प्रो. फकीर चंद, प्रो. नीरा राघव, प्रो. हरदीप जोशी, प्रो. अनुरेखा शर्मा, प्रो. सुमन ढांडा, प्रो. सुनीता दलाल, प्रो. अनिता मल्हान, डॉ. जितेंद्र भारद्वाज, डॉ. नीरज बातिश, डॉ. सलोनी दीवान, डॉ. अर्चना चौधरी सहित गणमान्य लोग मौजूद थे। कार्यक्रम का समापन राष्ट्रगीत के साथ हुआ।

KU Public speaking competition 'ROSTRUM' concludes



KURUKSHETRA, APR 27

The famous ROSTRUM public speaking competition of Kurukshetra University concluded with prize distribution function on Wednesday. Vice Chancellor KU Prof. Som Nath Sachdeva was the chief guest and gave away the prizes to the winners. The competition is held annually at three levels: department, faculty, and university. In all, there were 558 students who spoke on a variety of topics. Total prize money worth Rs. 2.60.000 was awarded to 256 students who won at different levels. The first prize at the university level was won by Ms Richa Tyagi of the Dept. of Mathematics, second prize was won by Ms Shweta from the Dept of Biochemistry and third went to Valuska Vats from Dept of Zoology. Congratulating the winners Prof Som Nath said, "This Public speaking competitions is highly motivating for young students. Importantly, it is non-adversarial format which hones research, organisation, and presentation skills of students. It promotes confidence, critical thinking and broadens participants' horizons and opportunities." "We have created more scope for the overall development of students in our Undergraduate programmes which have been designed and implemented as per NEP-2020. Along with public speaking and other skills, students learn about Indian Knowledge system, Modern Indian Languages, community engagement and critical thinking across disciplines," added Prof Som Nath.

Public speaking contest ends at K'shetra varsity

TRIBUNE NEWS SERVICE

KURUKSHETRA, APRIL 27

The Kurukshetra University's annual public speaking competition Rostrum concluded with prize distribution function on Wednesday.

Vice-Chancellor Prof Som Nath Sachdeva gave away prizes to the winners. The competition is held at three levels — department, faculty and university. A total of 558 students participated, and Rs 2.60 lakh worth prize money was awarded to 256 students who won at different levels.

The first prize at the university level was won by Richa Tyagi of the Department of Mathematics, second prize was won by Shweta from the Department of Biochemistry and the third prize went to Valuska Vats from the Department of Zoology.



कुरुक्षेत्र विश्वविद्यालय में एमएसएम प्रतियोगिता-वार्षिक पुरस्कार वितरण समारोह आयोजित

‘भाषा की जानकारी के साथ संवाद में अपनी संवेदनाएं व्यक्त करना अच्छे वक्ता की पहचान’

⇒ भाषण प्रतियोगिता युवा छात्रों के लिए आगे बढ़ने का प्रेरक संघ :
प्रो. सोमनाथ सचदेवा

जगमोहन न्यूज

कुरुक्षेत्र विश्वविद्यालय के कुलपति प्रोफेसर सोमनाथ सचदेवा ने एमएसएम प्रतियोगिता-वार्षिक पुरस्कार वितरण समारोह में उत्तीर्ण विजेताओं को बधाई देते हुए कहा कि यह सार्वजनिक भाषण प्रतियोगिता युवा छात्रों के लिए आगे बढ़ने का प्रेरक संघ है।

एमएसएम प्रतियोगिता विद्यार्थियों में आत्मविश्वास, प्रस्तुति कौशल तथा व्यक्तिगत कौशल में निखार लाने का कार्य करती है। यह प्रतिभागियों में आत्मोच्चतात्मक संघ को विकसित कर जागरूक नागरिकता भी निर्माण करती है ताकि वे राष्ट्रहित में महत्वपूर्ण योगदान दे सकें। इससे पहले सरस्वती पूजन, दीप प्रज्वलन एवं कुलगीत के साथ कार्यक्रम का शुभारंभ किया गया। कुलपति प्रो.

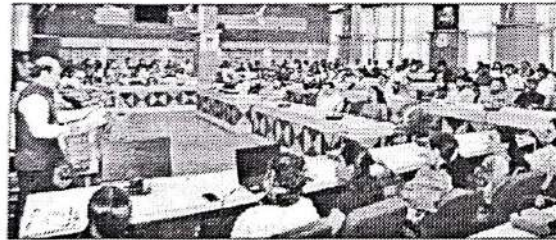

सोमनाथ ने कहा कि राष्ट्रीय शिक्षा नीति 2020 के अनुरूप शैक्षणिक प्रोग्राम के छात्रों के समग्र विकास के लिए कार्यक्रम को डिजाइन एवं कार्यान्वित किया गया है। उन्होंने कहा कि एमएसएम के तहत विद्यार्थियों में भाषण कौशल सहित अन्य कौशलों के साथ भारतीय ज्ञान प्रणाली, आधुनिक भारतीय भाषाओं, सामुदायिक जाग्रूथ जैसे महत्वपूर्ण विषयों पर जोर दिया गया है।

कुलपति प्रो. सोमनाथ सचदेवा ने कहा कि संवाद कला जितनी बारीकी से सीखनी पड़ती है उसी बारीकी से किसी भी विषय पर विस्तारपूर्वक जानकारी या अध्ययन करना पड़ता है। भाषा की जानकारी

के साथ-साथ अपने संवाद में संवेदनाएं व भाव भी व्यक्त करना एक अच्छे वक्ता की पहचान है। उन्होंने भाषण कला का विद्यार्थियों के जीवन में महत्व विद्यार्थियों के साथ साझा करते हुए उनके उच्चतर भविष्य की कामना की।

कार्यक्रम के विशिष्ट अतिथि वरुणसचिव प्रो. संजीव शर्मा ने भी विद्यार्थियों का उत्साहवर्धन करते हुए उन्हें बधाई दी। इसके पूर्व अधिष्ठाता छात्र कल्याण प्रो. शुचिरिमता ने अतिथियों का स्वागत किया तथा स्वागत चिन्ह के रूप में पीछे भेंट किए। प्रो. शुचिरिमता ने कहा कि रोट्टम एक भाषण प्रतियोगिता है जो तीन स्तर पर आयोजित की जाती है

कार्यक्रम में यह रहे मौजूद

संघ का संयोजन विधि विभाग की अनुनाय ने किया। उन मौके पर कुलपति प्रो. संजीव शर्मा, छात्र कल्याण अधिष्ठाता प्रो. शुचिरिमता, प्रो. एनके कल, प्रो. इंदरा सहनी, प्रो. अमबीर सिंह, प्रो. फकीर वद, प्रो. नीता राव, प्रो. हरीश जेठो, प्रो. अनुराधा शर्मा, प्रो. सुमन झा, प्रो. मुनीषा इन्द्र, प्रो. अर्चना भटनागर, डॉ. जितेंद्र भारद्वाज, डॉ. नीरज बाहिरा, डॉ. ललित कौशिक, डॉ. अर्चना कौशिक सहित मान्य लोग मौजूद थे। कार्यक्रम का समापन सद्गीत के साथ हुआ।

तथा कुरुक्षेत्र विश्वविद्यालय के सभी विभागों के विद्यार्थी इसमें भाग लेते हैं। इस वर्ष अलग-अलग स्तर पर 256 विजेताओं में 2 लाख 60 हजार 900 रुपये की धनराशि वितरित की गई। इस प्रतियोगिता के आयोजन में भी विद्यार्थियों की अहम भूमिका रहती है।

उन्होंने बताया कि एमएसएम गणित की छात्रा श्रद्धा त्यागी ने प्रथम, एमएससी बायो-कैमिस्ट्री की छात्रा श्रेया ने दूसरा तथा एमएससी जूलोजी की छात्रा वल्लुका बत्स ने तीसरा स्थान प्राप्त किया। वहीं वीएएलएलबी की जयश्री, एमएस कैमिस्ट्री की छात्रा शरति, वीएएलएलबी की छात्रा उषामना

तथा एमएससी बायोलॉजी की छात्रा दीपशिखा ने स्पेशल पुरस्कार प्राप्त किया। एमएसएम 2022 के संयोजक प्रो. अमबीर सिंह ने कार्यक्रम की रिपोर्ट में बताया कि पहले राउंड में 44 विभागों के 2471 विद्यार्थियों ने कार्यक्रम में भाग लिया और 451 विद्यार्थियों ने भाषण प्रतियोगिता में भाग लिया जिसमें से 123 को पुरस्कार मिला।

दूसरे राउंड में 81 वक्ता थे जिनमें से 26 विद्यार्थी विजेता हुए। इस तरह ओवरऑल तीनों राउंड में 2811 विद्यार्थियों ने प्रतिभागिता की और 558 ने भाषण दिया। सह-संयोजिका डॉ. अर्चना कौशिक ने धन्यवाद प्रस्ताव दिया।

के.यू. में रोस्ट्रम प्रतियोगिता- वार्षिक पुरस्कार वितरण समारोह आयोजित

कुरुक्षेत्र, 26 अप्रैल (धमीजा) : कुरुक्षेत्र विश्वविद्यालय विद्यार्थियों के सर्वांगीण विकास के लिए प्रतिबद्ध है तथा भाषण कला को बढ़ावा देने के लिए रोस्ट्रम जैसी प्रतियोगिताओं का आयोजन भविष्य में और भी बड़े स्तर पर करने की योजना है। यह विचार कुरुक्षेत्र विश्वविद्यालय के कुलपति प्रो. सोमनाथ सचदेवा ने बुधवार को रोस्ट्रम के विजेता विद्यार्थियों को पुरस्कार वितरित करते हुए अभिव्यक्त किए। इससे पहले सरस्वती पूजन, दीप प्रज्वलन एवं कुलगीत के साथ कार्यक्रम का शुभारंभ किया गया।

कुलपति ने कहा कि राष्ट्रीय शिक्षा नीति 2020 में भी मुख्य रूप से युवाओं के सर्वांगीण विकास, मूल्य परक शिक्षा, स्किल डैवलपमेंट, रोजगार परक शिक्षा, आचरण में नैतिक गुणों को आत्मसात कर उनके सशक्त चरित्र-निर्माण के लिए एक सतत् प्रयास है। इसी के मद्देनजर कुरुक्षेत्र विश्वविद्यालय अपने विद्यार्थियों के हितों के लिए संकल्पबद्ध है। कुलपति प्रो. सोमनाथ सचदेवा ने कहा कि संवाद कला जितनी बारीकी



पुरस्कार वितरण के दौरान कुवि कुलपति।

से सीखनी पड़ती है उसी बारीकी से किसी भी विषय पर विस्तारपूर्वक जानकारी का अध्ययन करना पड़ता है। भाषा की जानकारी के साथ-साथ अपने संवाद में संवेदनाएं व भाव भी व्यक्त करना एक अच्छे वक्ता की पहचान है।

कार्यक्रम के विशिष्ट अतिथि कुलसचिव प्रो. सजीव शर्मा ने भी विद्यार्थियों का उत्साहवर्धन करते हुए उन्हें बधाई दी। इसके पूर्व अधिष्ठाता छत्रकल्याण प्रो. शुचिस्मिता ने अतिथियों का स्वागत किया तथा स्वागत चिन्ह के रूप में पौधे भेंट किए। इस वर्ष अलग-अलग स्तर पर 256 विजेताओं में 2

लाख 60 हजार 900 रुपए की धनराशि वितरित की गई। रोस्ट्रम 2022 के संयोजक प्रो. ओमवीर सिंह ने कार्यक्रम की रिपोर्ट में बताया कि पहले राउंड में 44 विभागों के 2471 विद्यार्थियों ने कार्यक्रम में भाग लिया और 451 विद्यार्थियों ने भाषण प्रतियोगिता में भाग लिया जिसमें से 123 को पुरस्कार मिला। दूसरे राउंड में 81 वक्ता थे जिनमें से 26 विद्यार्थी विजेता हुए। इस तरह ओवरऑल तीनों राउंड में 2811 विद्यार्थियों ने प्रतिभागिता की और 558 ने भाषण दिया। सह-संयोजिका डा. अर्चना गौधरी ने धन्यवाद प्रस्ताव दिया।

STUDENTS PARTICIPATION AND ACTIVITIES DURING THE SEESION 2022-23 ORGANIZED/PERTICIPATE BY KURUKSHETRA UNIVERSITY KURUKSHETRA

Year	Name of the Award/Medal	Team/ Individual	Inter University/State National/International	Name of the Event	Name of the students
2022-23		Individual	Ratnawali Haryana Day State Level Festival 2022-23 28-31 October 2022		
	First Prize	Individual	KU Campus Kurukshetra	Haryanvi Gazal	Ekta
	Third Prize	Individual	KU Campus Kurukshetra	Solo Dance Male	Aakash (Dancer) Aman (Singer)
	Second Prize	Individual	KU Campus Kurukshetra	Solo Dance Female	Chetna (Dancer) Ekta (Singer)
	Second Prize	Individual	KU Campus Kurukshetra	Haryanvi Bhajan	Aman
	Third Prize	Individual	KU Campus Kurukshetra	Mono Acting Haryanvi	Love
	First Prize	Individual	KU Campus Kurukshetra	Mono acting Haryanvi	Lalit
	First Prize	Individual	KU Campus Kurukshetra	Haryanvi Poetry	Lalit
	First Prize	Individual	KU Campus Kurukshetra	Tie of Haryanvi Pagari	Ankit Kumar
	Third Prize	Individual	KU Campus Kurukshetra	Folk Costume Female	Namrata
	First Prize	Individual	KU Campus Kurukshetra	On the Spot Painting	Jagdeep Singh
	First Prize	Individual	KU Campus Kurukshetra	Exhibition of Painting	Gaurav Kashyap
	Second Prize	Individual	KU Campus Kurukshetra	Exhibition of Painting	Pankaj Kumar
	Second Prize	Individual	KU Campus Kurukshetra	Haryanvi Lok Geet	Aman Kumar
	Second Prize	Individual	KU Campus Kurukshetra	Haryanvi Folk Inst Solo	Mannan
	Second Prize	Group Event	KU Campus Kurukshetra	Haryanvi Pop Song	Second Prize
	Second Prize	Group Event	KU Campus Kurukshetra	Haryanvi Group Song	Second Prize
	Second Prize	Group Event	KU Campus Kurukshetra	Group Dance Haryanvi	Second Prize
	Third Prize	Group Event	KU Campus Kurukshetra	Haryanvi Choreography	Third Prize
	Second Prize	Group Event	KU Campus Kurukshetra	Haryanvi Orchestra	Second Prize
First Prize	Group Event	KU Campus Kurukshetra	Haryanvi Fashion Show	First Prize	
Second Prize	Group Event	KU Campus Kurukshetra	Haryanvi Loor Dance	Second Prize	

STUDENTS PARTICIPATION AND ACTIVITIES DURING THE SEESION 2022-23 ORGANIZED/PERTICIPATE BY KURUKSHETRA UNIVERSITY KURUKSHETRA

Session 2022-23	2 nd Position	Group Event	North West Zone Inter University Youth Festival held at MM University Mulana from 24-28 January 2023	Over All Runner Runner up Trophy KUK	
	1 st Position	Group Event		Theater Event Trophy	
	1 st Position	Group Event		Music Event Over All Trophy	
	1 st Position	Group Event		Fine Arts Over All Trophy	
	2 nd Position	Group Event		Procession	
	1 st Position	Group Event		1 Folk Tribal Dance	
	1 st Position	Group Event		2 One Act Play	
	3 rd Position	Group Event		3 Mime	
	1 st Position	Group Event		4 Skit	
	1 st Position	Group Event		5 Mimicry	
	1 st Position	Group Event		6 Folk Orchestra	
	3 rd Position	Individual		7 Classical Vocal Solo	
	3 rd Position	Individual		8 Classical Inst Solo P'	
	2 nd Position	Individual		9 Classical Inst Solo NP	
	2 nd Position	Individual		10 West Vocal Solo	
	2 nd Position	Individual		11 West Inst Solo	
	3 rd Position	Individual	12 On The Spot Painting		
	2 nd Position	Individual	13 Clay Modeling		
	1 st Position	Individual	14 Installation		
	3 rd Position	Individual	15 Photography		
		Group			
		Individual			

STUDENTS PARTICIPATION AND ACTIVITIES DURING THE SEESION 2022-23 ORGANIZED/PERTICIPATE BY KURUKSHETRA UNIVERSITY KURUKSHETRA

		Group Individual			
	Presentation	Group	International Youth Festival by AIU held at Lovely Professional University Phagwara Ludhiana from 6-8 April 2023	Folk Orchestra Folk Tribal Dance	



DIRECTOR